User's Guide

Publication number E3497-97006
May 2000

For Safety information, Warranties, and Regulatory information, see the pages behind the index.

© Copyright Agilent Technologies 1994-2000
All Rights Reserved

Emulation for the Motorola MPC800 Embedded PowerPC

Motorola Embedded PowerPC MPC860/821 Emulation—At a Glance

This manual describes how to set up several Agilent Technologies emulation products: an emulation probe, an emulation module, and an emulation migration. These emulators provide a low-cost way to debug embedded software for Motorola MPC860 and MPC821 Embedded PowerPC microprocessors. The emulator lets you use the target processor's built-in background debugging features, including run control and access to registers and memory. A high-level source debugger can use the emulator to debug code running on the target system.

You can connect the emulator to an analysis probe or you can connect it to a debug port on the target system through the provided target interface module (TIM). The emulator can be controlled by a debugger on a host computer or by the Emulation Control Interface on an Agilent Technologies 16600A/700A-series logic analysis system.

Emulation Probe

The emulation probe is a stand-alone emulator.

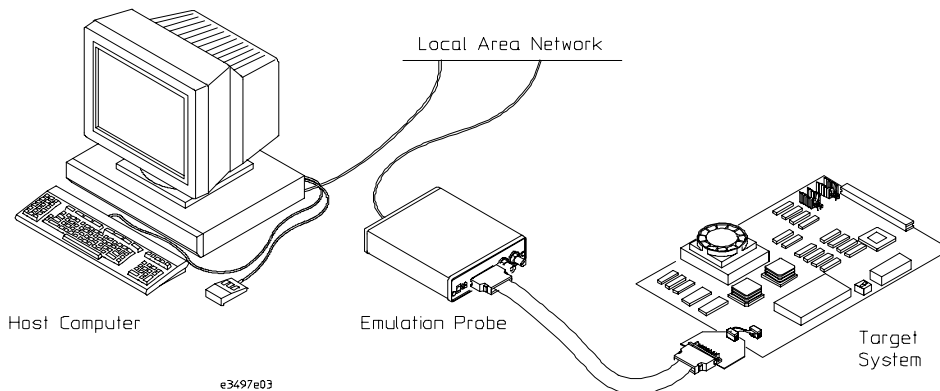

Emulation Module

The emulation module plugs into your Agilent Technologies 16600A/700A-series logic analysis system frame.

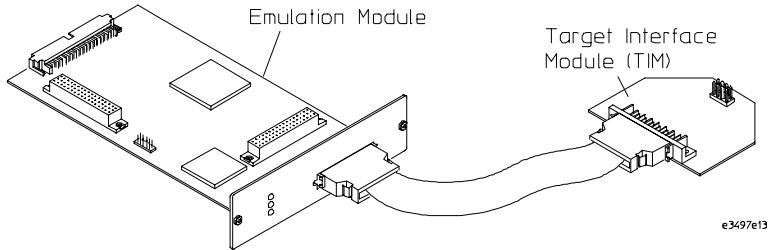

You can connect the emulation module to an analysis probe or you can connect it to a debug port on the target system through the provided target interface module (TIM).

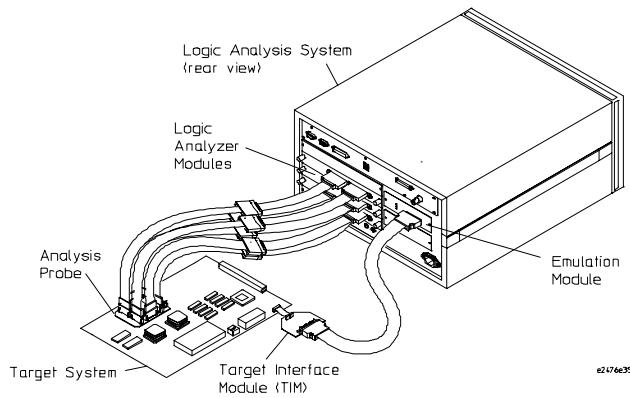

Emulation Migration

The emulation migration includes a target interface module and firmware. Use the emulation migration if you already have an emulation probe or an emulation module for another processor.

In This Book

This book documents the following products:

Emulation Probe

Processors supported	Product ordered	Includes
MPC860/821/801/850 Up to 66 MHz	Agilent Technologies E5900A Option #080	Agilent Technologies E3497A emulation probe, Agilent Technologies E3497A target interface module (TIM)

Emulation Module

Processors supported	Product ordered	Includes
MPC860/821/801/850 Up to 66 MHz	Agilent Technologies E5901A Option #080	Agilent Technologies 16610A emulation module, Agilent Technologies E3497A target interface module (TIM)

Emulation Migration

Processors supported	Product ordered	Includes
MPC860/821/801/850 Up to 66 MHz	Agilent Technologies E5902A Option #080	Agilent Technologies E3497A target interface module (TIM)

Contents

1 Overview 13

Setup Flowchart 15

Emulation Probe 16

Equipment supplied 16

Minimum equipment required 18

To connect the emulation probe to a power source 18

Emulation probe connection sequence 20

Emulation Module 21

Equipment supplied 21

Minimum equipment required 22

Emulation Migration 23

Equipment supplied 23

Minimum equipment required 24

Where to find emulation migration firmware 24

Additional Information Sources 25

2 Connecting the Emulation Probe to a LAN 27

Setting Up a LAN Connection to a PC or Workstation 29

- To obtain an IP address 30
- To configure LAN parameters using the built-in terminal interface 31
- To configure LAN parameters using BOOTP 34
- To set the 10BASE-T configuration switches 36
- To verify LAN communications 37

Setting Up a Serial Connection 38

- To set the serial configuration switches 39
- To connect a serial cable 39
- To verify serial communications 41

3 Installing the Emulation Module 43

Installing the Emulation Module 44

- To install the emulation module in a 16700A-series logic analysis system or a 16701A expansion frame 45
- To install the emulation module in a 16600A-series logic analysis system 47

4 Installing Software on a 16600A/700A 49

- To list software packages which are installed (16600A/700A) 51
- To install the software from CD-ROM (16600A/700A) 52

5 Connecting and Configuring the Emulator 53

Connecting and Configuring the Emulator 54

Using the Emulation Control Interface 55

To start the Emulation Control Interface from the main System window (emulation module) 56

To start the Emulation Control Interface from the Workspace window (emulation module) 57

To start the Emulation Control Interface (emulation probe) 57

Designing a Target System for the Emulator 58

Debug port connections 59

Connecting the Emulator to the Target System 61

To connect to a target system using a debug port 62

To connect to a target system using an analysis probe 63

Configuring the Emulator 64

To configure using the Emulation Control Interface 66

To configure using the built-in commands 67

To configure using a debugger 68

To configure the processor type 69

To configure the processor clock speed 69

To configure restriction to real-time runs 70

To configure the default reset level 70

To view the download speed 71

To configure the "Break In" type 71

To configure the Trigger Out BNC

(Emulation Probe Only) 72

To configure the Trigger In BNC

(Emulation Probe Only) 72

To configure the emulator's copy of the IMMR register 73

- To configure the emulator's copy of the SYPCR register 73
- To configure the emulator's copy of the DER register 73
- To disable configuration registers 74
- To configure a Motorola 860ADS target system 75

Testing the emulator and target system 78

- To test memory accesses 78
- To test with a running program 78

6 Using the Emulator with a Debugger 81

Setting up Debugger Software 85

- To connect the logic analysis system to the LAN 86
- To change the port number of an emulator 87
- To verify communication with the emulator 88
- To export the logic analysis system's display to a workstation 89
- To export the logic analysis system's display to a PC 90

7 Using the Analysis Probe and Emulation Module Together 91

Triggering the Emulation Module from the Analyzer 95

- To stop the processor when the logic analyzer triggers on a line of source code (Source Viewer window) 95
- To stop the processor when the logic analyzer triggers (Intermodule window) 96
- To minimize the "skid" effect 97
- To stop the analyzer and view a measurement 97

- Tracing until the processor halts 98
 - To capture a trace before the processor halts 98
- Triggering the Logic Analyzer from the Emulation Module 99
 - To trigger the analyzer when the processor halts 103
 - To trigger the analyzer when the processor reaches a breakpoint 104

8 Updating Firmware 107

- Emulation Probe Firmware 109
 - To display current firmware version information 109
 - To update firmware for an emulation probe 109
 - If there is a power failure during a firmware update 109
- Emulation Module Firmware 110
 - To display current firmware version information 110
 - To update firmware for an emulation module using the Emulation Control Interface 110
 - To update firmware for an emulation module using the Setup Assistant 111

9 Specifications and Characteristics 113

- Processor Compatibility 114
- Emulation Probe Electrical Characteristics 114
 - BNC, labeled TRIGGER OUT 114
 - BNC, labeled BREAK IN 114
 - Communications 114
 - Accessory Power Out 115
 - Power Supply 115
- Emulation Probe and Emulation Module Electrical Characteristics 115

Emulation Probe Environmental Characteristics 116
 Temperature 116
 Altitude 116
 Relative Humidity 116
Emulation Module Environmental Characteristics 116

10 Troubleshooting the Emulator 117

Troubleshooting Guide 119

Status Lights 120

Emulator Built-in Commands 123
 To telnet to the emulator 123
 To use the built-in commands 124

Problems with the LAN Interface (Emulation Probe Only) 126
 If you cannot verify LAN communication 126
 If you have LAN connection problems 127
 If the "POL" LED is lit 128
 If it takes a long time to connect to the network 128

Problems with the Serial Interface (Emulation Probe Only) 129
 If you cannot verify RS-232 communication 129
 If you have RS-232 connection problems with the MS Windows Terminal
 program 129

Problems with the Target System 131
 What to check first 131
 To interpret the initial prompt 133
 If interrupts are non-recoverable 135
 If hardware breakpoints have no effect 135
 If the target resets itself 136

If running from reset causes problems	137
If you see the "!ASYNC_STAT 173!" error message	137
If there are problems with the debug port signals	137
To test the target system	138
Problems with the LAN Interface	139
If LAN communication does not work	139
If it takes a long time to connect to the network	140
Problems with the Emulation Probe	141
To run the power up self test	141
To execute the built-in performance verification test (emulation probe only)	143
To perform the PV tests through the logic analysis system	143
Additional PV Tests	143
TEST 2: LAN 10BASE2 Feedback Test failed	145
Test 3: 10BaseT Feedback Test failed	146
E3499A TEST 4: Break In and Trigger Out BNC Feedback Test	146
TEST 5: Target Probe Feedback Test	147
Problems with the Emulation Module	148
To run the built-in performance verification test using the logic analysis system (emulation module only)	148
To run complete performance verification tests using a telnet connection (emulation module only)	149
If a performance verification test fails	150
Returning Parts to Agilent Technologies for Service	151
To return a part to Agilent Technologies	151
To obtain replacement parts	152
Cleaning the Instrument	153

Glossary 155

Index 159

Overview

Overview

This chapter describes:

- Setup Checklist
- Equipment used with the emulation probe
- Connection sequences for the emulation probe
- Equipment used with the emulation module
- Additional information sources

Setup Flowchart

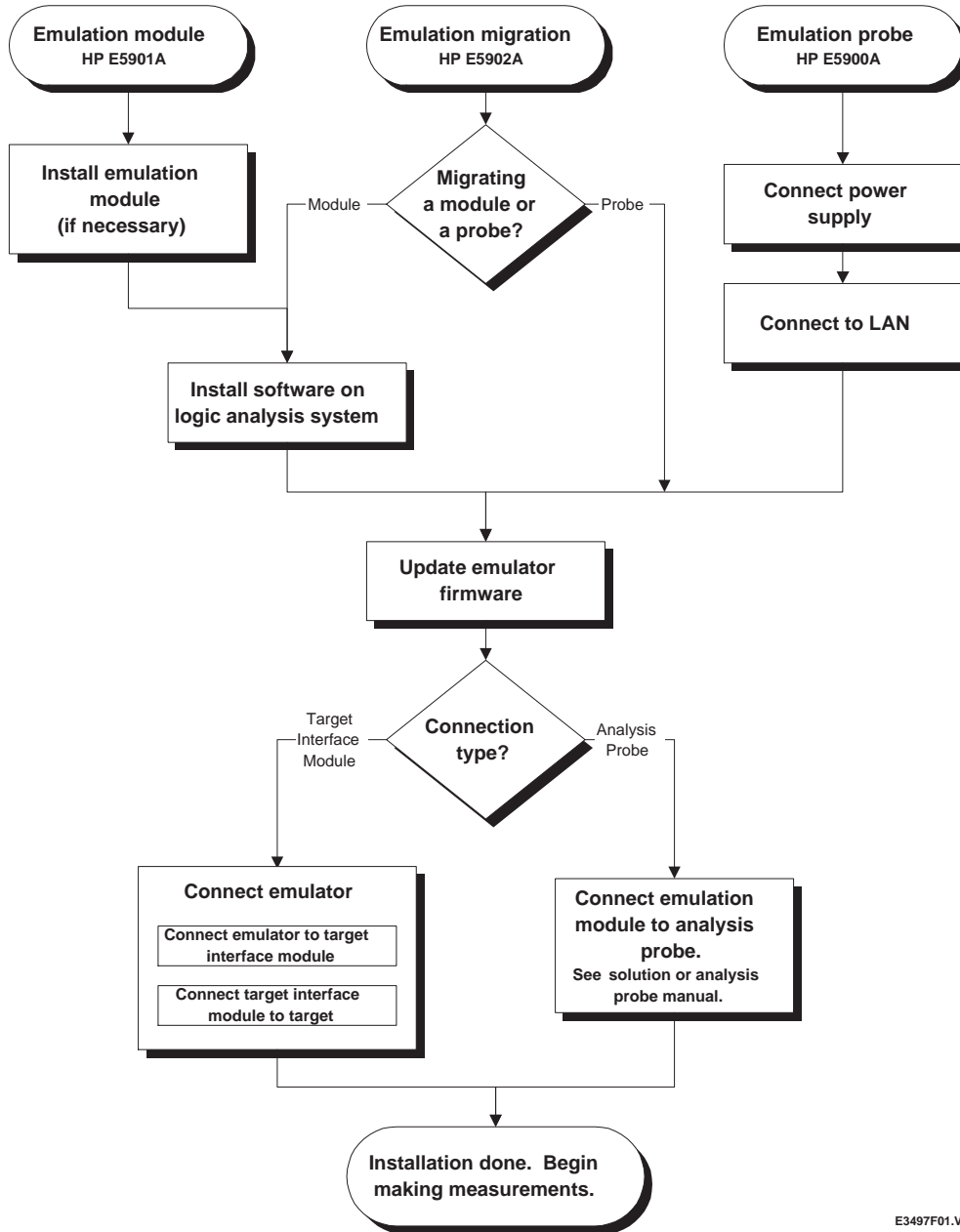

E3497F01.VSD

Emulation Probe

This section lists equipment supplied with the emulation probe and equipment requirements for using the emulation probe.

Equipment supplied

The equipment supplied with the emulation probe is shown in the illustration on the next page. It is listed below:

- An emulation probe.
- A 12V power supply for the emulation probe.
- A power cord.
- A target interface module (TIM) circuit board.
- A emulator loopback test board (Agilent part number E3496-66502).
- Firmware for the emulation probe on 3.5-inch disks.
- A 50-pin ribbon cable for connecting the emulation module to the target interface module or the Agilent Technologies E2476A analysis probe.
- A 10-pin ribbon cable for connecting the target interface module to the target system.
- This User's Guide.

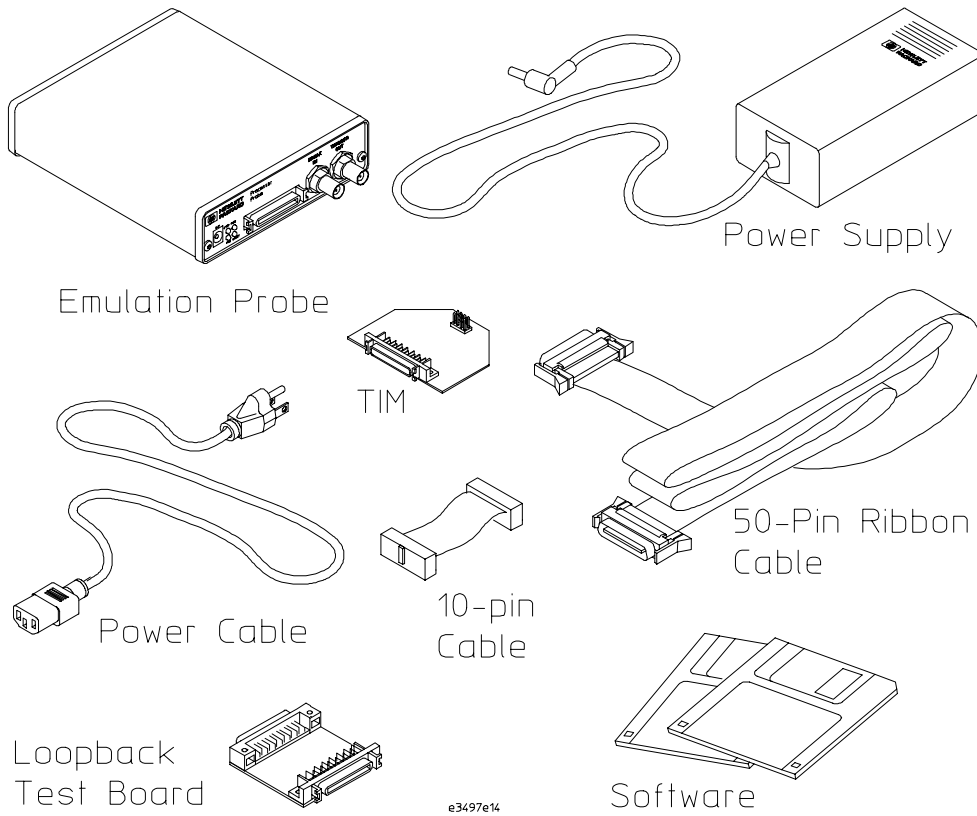

Equipment Supplied with the Emulation Probe

Minimum equipment required

The following equipment is required to use the emulation probe:

- A method for connecting to the target system. The Agilent Technologies E2476A analysis probe provides a debug port connector. You can also design a debug port connector on the target system.
- A host computer, such as a PC or workstation. You can also connect the emulation probe to an Agilent Technologies 16600A or 16700A logic analysis system.
- A LAN (local area network) to connect the emulation probe to the host computer.
- A user interface on the host computer, such as a high-level source debugger or the logic analysis system's Emulation Control Interface.

To connect the emulation probe to a power source

The emulation probe does not have an On/Off switch. To turn the emulation probe on or off, plug or unplug it from the power supply.

The emulation probe is shipped from the factory with a power supply and cord appropriate for your country. If the cord you received is not appropriate for your electrical power outlet type, contact your Agilent Technologies sales and service office.

Warning

Use only the supplied Agilent Technologies power supply and cord. Failure to use the proper power supply could result in electric shock.

Caution

Use only the supplied Agilent Technologies power supply and cord. Failure to use the proper power supply could result in equipment damage.

1 Connect the power cord to the power supply and to a socket outlet.

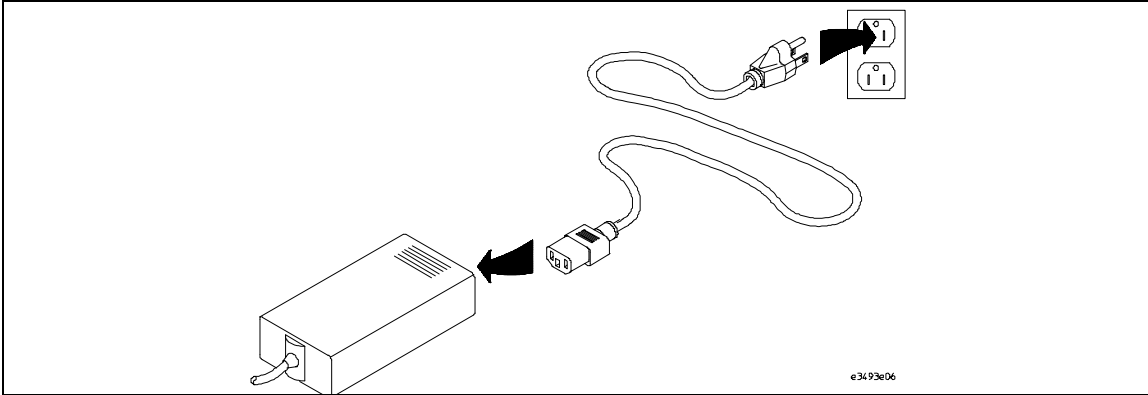

2 Connect the 12V power cord to the back of the emulation probe.

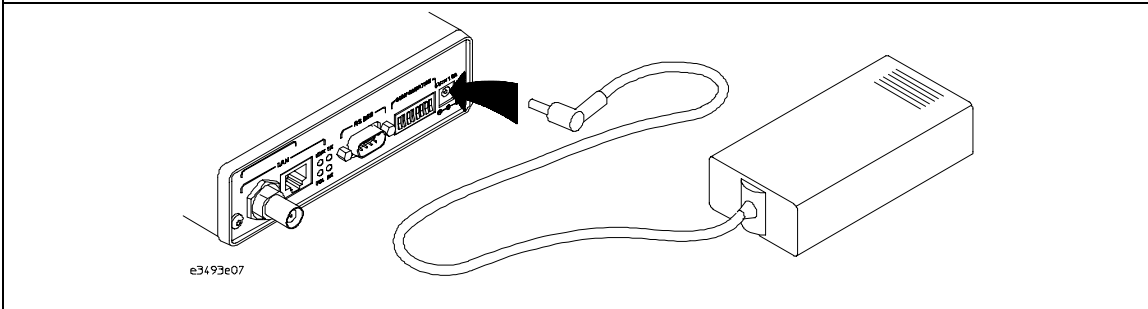

The power light on the target side of the emulation probe will light. The emulation probe does not have an On/Off switch.

With all components connected, power on your system in the following order:

- 1** Logic analyzer, if you are using one.
- 2** Emulation probe.
- 3** Your target system.

Power off your system in the following order:

- 1** Your target system
- 2** Emulation probe.
- 3** Logic analyzer, if you are using one.

Emulation probe connection sequence

Disconnect power from the target system, emulation probe, and logic analyzer before you make or break connections.

- 1** Connect the emulation probe to a LAN (page 27).
- 2** Connect the emulation probe to your target system (page 44).
- 3** Configure the emulation probe (page 64).

Emulation Module

This section lists equipment supplied with the emulation module and lists the minimum equipment required to use the emulation module.

Equipment supplied

The equipment supplied with your emulation module includes:

- An Agilent Technologies 16610A emulation module. If you ordered an emulation module as part of your Agilent Technologies 16600A or 16700A logic analysis system, it is already installed in the frame.
- A target interface module (TIM) circuit board.
- A emulation module loopback test board (Agilent part number E3496-66502).
- Firmware for the emulation module and/or updated software for the Emulation Control Interface on a CD-ROM.
- A 50-pin ribbon cable for connecting the emulation module to the target interface module or the Agilent Technologies E2476A Analysis Probe.
- A 10-pin ribbon cable for connecting the target interface module to the target system.
- One Torx T-8, one Torx T-10, and one Torx T-15 screwdriver (if the emulation module was not installed at the factory).
- This User's Guide.

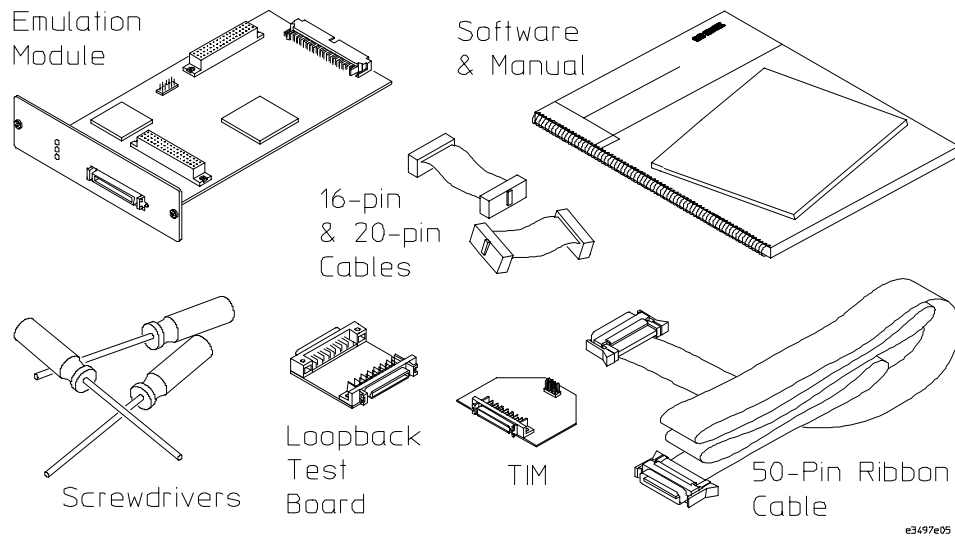

Equipment Supplied with the Agilent Technologies E3497A Emulation Module

Minimum equipment required

The following equipment is required to use the emulation module:

- A method for connecting to the target system. The Agilent Technologies E2476A analysis probe provides a debug port connector. You can also design a debug port connector on the target system.
- An Agilent Technologies 16600A or 16700A logic analysis system.
- A user interface, such as a high-level source debugger or the logic analysis system's Emulation Control Interface.

Emulation Migration

This section lists equipment supplied with the emulation migration and lists the minimum equipment required to use the emulation migration.

Equipment supplied

The equipment supplied with your emulation migration includes:

- A target interface module (TIM) circuit board.
- Firmware for the emulation module and/or updated software for the Emulation Control Interface on a CD-ROM.
- Firmware for the emulation probe on a floppy disk.
- A 10-pin ribbon cable for connecting the target interface module to the target system.
- This User's Guide.

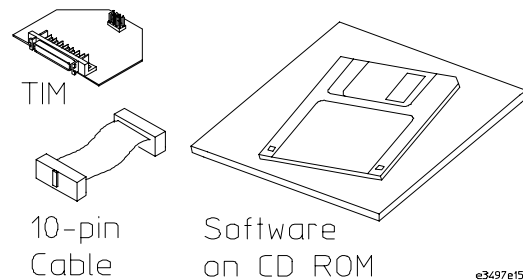

Minimum equipment required

The following equipment is required to use the emulation migration:

- An emulation module or emulation probe.
 - A 50-pin data cable (supplied with the emulation module or probe).
 - A method for connecting to the target system. The Agilent Technologies E2476A analysis probe provides a debug port connector. You can also design a debug port connector on the target system. See Chapter 8 provides information on designing a debug port on the target system.
 - A host computer such as a PC, a workstation, or an Agilent Technologies 16600A or 16700A logic analysis system.
 - A user interface, such as a high-level source debugger or the logic analysis system's Emulation Control Interface.
-

Where to find emulation migration firmware

To change the personality of your emulation probe or emulation module for a new processor, you need to install new firmware.

If you have an emulation probe

Install the firmware from the floppy disk. The README file on the floppy disk contains instructions for installing the firmware using a PC or workstation.

If you have an emulation module

Use the CD-ROM to install the appropriate processor support package (see page 49). This package installs the firmware on the hard disk of your Agilent Technologies 16600A/700A-series logic analysis system.

Additional Information Sources

Additional or updated information can be found in the following places:

Newer editions of this manual may be available. Contact your local Agilent Technologies representative.

If you have an analysis probe, the instructions for connecting the probe to your target microprocessor are in the analysis probe documentation. The ***Solutions for the Motorola Embedded PowerPC MPC860/821 User's Guide*** provides information on using the analysis probe and emulation module together.

Application notes may be available from your local Agilent Technologies representative or on the World Wide Web at:

<http://www.agilent.com/find/logicanalyzer>

If you have an Agilent Technologies 16600A or 16700A logic analysis system, the **online help** for the Emulation Control Interface has additional information on using the emulator.

The **measurement examples** include valuable tips for making emulation and analysis measurements. You can find the measurement examples under the system help in your Agilent Technologies 16600A/700A logic analysis system.

Connecting the Emulation Probe to a LAN

Connecting the Emulation Probe to a LAN

You can connect your PC or workstation to the emulation probe via a serial or LAN connection.

Serial connection

A serial connection allows you to complete all of the performance verification tests. Other use of the serial port is not supported: performance over a serial connection, especially if you are downloading code, may be unacceptably slow.

LAN connection

A LAN connection will allow you to make your measurements quickly and easily. A few of the performance verification tests cannot be run over a LAN.

Recommended connection

Use a LAN connection for routine use, and a serial connection for LAN configuration and for troubleshooting.

See Also

For information on LAN connections to an emulation *module*, see "Using the Emulator with a Debugger" beginning on page 81.

Setting Up a LAN Connection to a PC or Workstation

The emulation probe has two LAN connectors:

- A BNC connector that can be directly connected to a IEEE 802.3 Type 10BASE2 cable (ThinLAN). When using this connector, the emulation probe provides the functional equivalent of a Medium Attachment Unit (MAU) for ThinLAN.
- An IEEE 802.3 Type 10BASE-T (StarLAN) connector.

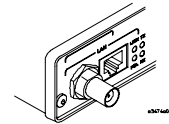

Use either the 10BASE2 or the 10BASE-T connector. Do *not* use both. The emulation probe will not work with both connected at the same time.

You must assign an IP address (Internet address) to the emulation probe before it can operate on the LAN. You can also set other network parameters such as a gateway address. The IP address and other network parameters are stored in nonvolatile memory within the emulation probe.

The emulation probe automatically sets a subnet mask based on the subnet mask used by other devices on the network.

You can configure LAN parameters in any of the following ways:

- Using the built-in terminal interface over a serial connection. This is the most reliable method.
- Using BOOTP. BOOTP is part of the HP-UX, SunOS, and Solaris operating systems.

To obtain an IP address

1 Obtain the following information from your local network administrator or system administrator:

- An IP address for the emulation probe.

You can also use a "LAN name" for the emulation probe, but you must configure it using the integer dot notation (such as 127.0.0.1).

- The gateway address.

The gateway address is an IP address and is entered in integer dot notation. The default gateway address is 0.0.0.0, which allows all connections on the local network or subnet. If connections are to be made to workstations on other networks or subnets, this address must be set to the address of the gateway machine.

2 Find out whether port numbers 6470 and 6471 are already in use on your network.

The host computer interfaces communicate with the emulation probe through two TCP service ports. The default base port number is 6470. The second port has the next higher number (default 6471).

The default numbers (6470, 6471) can be changed if they conflict with some other product on your network.

To change the port numbers, see page 31. If you have already set the IP address, you can use a telnet connection instead of a serial connection to connect to the emulation probe.

3 Write down the link-level address of the emulation probe.

You will need this address if you use BOOTP to set the IP address.

The link-level address (LLA) is printed on a label above the LAN connectors on the emulation probe. This address is configured in each emulation probe shipped from the factory and cannot be changed.

IP Address of Emulation probe
LAN Name of Emulation Probe
Gateway Address
Link-Level Address of Emulation Probe

To configure LAN parameters using the built-in terminal interface

- 1 Set configuration switches S1 through S4 to CLOSED, and set the other switches as appropriate for your serial interface.

Switch settings are printed on the bottom of the emulation probe. If you will use a baud rate of 9600 baud, set the switches like this:

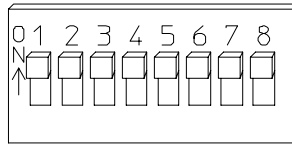

e3490b05

- 2 Connect an ASCII terminal (or terminal emulator) to the emulation probe's RS-232 port with a 9-pin RS-232 cable.

Complete instructions for setting up a serial connection begin on page 38.

- 3 Plug in the emulation probe's power cord. Press the terminal's <RETURN> key a couple times. You should see a prompt such as "p>", "?>", or "c>".

At this point, you are communicating with the emulation probe's built-in terminal interface.

- 4 Display the current LAN configuration values by entering the **lan** command:

```
R>lan
lan is disabled
lan -i 0.0.0.0
lan -g 0.0.0.0
lan -p 6470
Ethernet Address : 08000903212f
```

The "lan -i" line shows the current IP address (IP address) of the emulation probe.

The Ethernet address, also known as the link level address, is preassigned at the factory, and is printed on a label above the LAN connectors.

- 5 Enter the following command:

```
lan -i <internet> [-g <gateway>] [-p <port>]
```

The lan command parameters are:

-i <internet> The IP address which you obtained from your network administrator.

- g <gateway> The gateway address. Setting the gateway address allows access outside your local network or subnet.
- p <port> This changes the base TCP service port number.

The default numbers (6470, 6471) can be changed if they conflict with some other product on your network. TCP service port numbers must be greater than 1024. If you change the base port, the new value must also be entered in the /etc/services file on the host computer. For example, you could modify the line:

```
hp64700    6470/tcp
```

The IP address and any other LAN parameters you change are stored in nonvolatile memory and will take effect the next time the emulation probe is powered off and back on again.

6 Disconnect the power cord from the emulation probe, and connect the emulation probe to your network.

This connection can be made by using either the 10BASE-T connector or the 10BASE2 (BNC) connector on the emulation probe. Do not use both connectors at the same time.

7 Set the configuration switches to indicate the type of connection that is to be made.

Switch S1 must be set to OPEN, indicating that a LAN connection is being made.

Switch S5 should be CLOSED if you are connecting to the BNC connector:

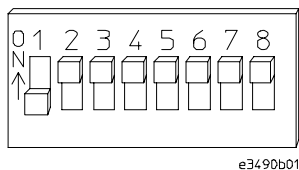

Switch S5 should be OPEN if you are connecting to the 10BASE-T connector:

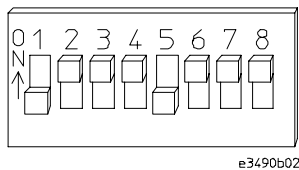

Set all other switches to CLOSED.

8 Connect the power cord to the emulation probe.

- 9** Verify your emulation probe is now active and on the network. See "To verify LAN communications" on page 37.

Once you have set a valid IP address, you can use the telnet utility to connect to the emulation probe, and use the lan command to change LAN parameters.

Example

To assign an IP address of 192.6.94.2 to the emulation probe, enter the following command:

```
R>lan -i 192.6.94.2
```

Now, cycle power on the emulation probe so that the new address will take effect.

See Also

"Troubleshooting," page 117, if you have problems verifying LAN communication.

To configure LAN parameters using BOOTP

Use this method only on a workstation which is running bootpd, the BOOTP daemon.

1 Make sure that BOOTP is enabled on your host computer.

If the following commands yield the results shown below, the BOOTP protocol is enabled:

```
$ grep bootp /etc/services
bootps      67/udp
bootpc      68/udp
$ grep bootp /etc/inetd.conf
bootps dgram udp wait root /etc/bootpd bootpd
```

If the commands did not yield the results shown, you must either add BOOTP support to your workstation or use a different method to configure the emulation probe LAN parameters.

2 Add an entry to the host BOOTP database file, /etc/bootptab. For example:

```
# Global template for options common to all Agilent 64700
# emulators and Emulation Probes.
# Use a different gateway addresses if necessary.
hp64700.global:\
    :gw=0.0.0.0:\
    :vm=auto:\
    :hn:\
    :bs=auto:\
    :ht=ether

# Specific emulator entry specifying hardware address
# (link-level address) and ip address.
hprobe.div.hp.com:\
    :tc=hp64700.global:\
    :ha=080009090B0E:\
    :ip=192.6.29.31
```

In this example, the "ha=080009090B0E" identifies the link-level address of the emulation probe. The "ip=192.6.29.31" specifies the IP address that is assigned to the emulation probe. The node name is "hprobe.div.hp.com".

3 Connect the emulation probe to your network.

This connection can be made by using either LAN connector on the emulation probe.

4 Set the configuration switches to indicate the type of connection that is to be made.

Switch S1 must be set to OPEN, indicating that a LAN connection is being made.

Switch S6 must be set to OPEN to enable BOOTP mode.

Switch S5 should be set to CLOSED if you are connecting to the BNC connector

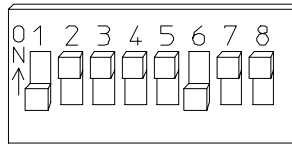

e3490b03

Switch S5 should be set to OPEN if you are connecting to the 10BASE-T connector.

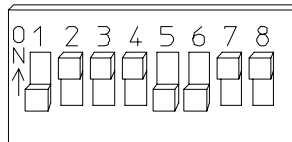

e3490b04

Set all other switches to CLOSED.

5 Connect the power cord to the emulation probe.

Verify that the power light stays on after 10 seconds.

The IP address will be stored in EEPROM.

6 Set switch S6 back to CLOSED.

Do this so that the emulation probe does not request its IP address each time power is cycled. The IP address is stored in EEPROM, so BOOTP does not need to be run again. Leaving this switch on will result in slower performance, increased LAN traffic, and even failure to power up (if the BOOTP server becomes inactive).

7 Verify your emulation probe is now active and on the network. See "To verify LAN communications" on page 37.

See Also

For additional information about using bootpd, refer to the bootpd (1M) man page.

To set the 10BASE-T configuration switches

Set switches S7 and S8 to CLOSED unless one of the following conditions is true:

- **If the LAN cable exceeds the standard length, set switch S7 to OPEN.**
The emulation probe has a switch-selectable, twisted-pair receiver threshold. With switch S7 set to OPEN, the twisted-pair receiver threshold is lowered by 4.5 dB. This should allow you to use cable lengths of up to about 200 meters. If you use a long cable, you should consult with your LAN cabling installer to ensure that:
 - The device at the other end of the cable has long cable capability, and
 - The cable is high-grade, low-crosstalk cable with crosstalk attenuation of greater than 27.5 dB.

When switch S7 is set to CLOSED, the LAN port operates at standard 10BASE-T levels. A maximum of 100 meters of UTP cable can be used.

- **If your network doesn't support Link Beat integrity checking or if the emulation probe is connected to a non 10BASE-T network (such as StarLAN) set this switch to LINK BEAT OFF (0 or OPEN).**

In normal mode (switch S8 set to CLOSED), a link integrity pulse is transmitted every 15 milliseconds in the absence of transmitted data. It expects to receive a similar pulse from the remote MAU. This is the standard link integrity test for 10BASE-T networks. If your network doesn't support the Link Beat integrity checking or if the Software Probe is used on a non 10BASE-T network (such as StarLAN) set this switch to LINK BEAT OFF (OPEN).

Note

Setting switch S8 to OPEN when Link Beat integrity checking is required by your network will cause the remote MAU to disable communications.

To verify LAN communications

- 1 Verify your emulation probe is now active and on the network by issuing a **telnet** to the IP address.

This connection will give you access to the emulation probe's built-in terminal interface.

- 2 To view the LAN parameters, enter the **lan** command at the terminal interface prompt.

- 3 To exit from this telnet session, type <CTRL>D at the prompt.

The best way to change the emulation probe's IP address, once it has already been set, is to telnet to the emulation probe and use the terminal interface **lan** command to make the change. Remember, after making your changes, you must cycle power or enter a terminal interface **init -p** command before the changes take effect. Doing this will break the connection and end the telnet session.

If You Have Problems

If you encounter problems, refer to the "Problems" chapter (page 117).

Example

```
$ telnet 192.35.12.6

R>lan
lan is enabled
lan -i 192.35.12.6
lan -g 0.0.0.0
lan -p 6470
Ethernet Address : 08000F090B30
```

Setting Up a Serial Connection

To set up a serial connection, you will need to:

- Set the serial configuration switches
- Connect a serial cable between the host computer and the emulation probe
- Verify communications

Serial connections on a workstation

If you are using a UNIX workstation as the host computer, you need to use a serial device file. If a serial device file does not already exist on your host, you need to create one. Once it exists, you need to ensure that it has the appropriate permissions so that you can access it. See the system documentation for your workstation for help with setting up a serial device.

Serial connections on a PC

Serial connections are supported on PCs. You must use hardware handshaking if you will use the serial connection for anything other than setting LAN parameters.

If you are using a PC as the host computer, you do not need to set up any special files.

To set the serial configuration switches

- 1 Set switch S1 to CLOSED (RS-232).
- 2 Set switches S2-S4 to CLOSED.
- 3 Set switch S5 to CLOSED (HW HANDSHAKE ON) if your serial interface uses the DSR:CTS/RTS lines for flow control. Set S5 to OPEN (HW HANDSHAKE OFF) if your serial interface uses software flow control (XON/XOFF).

If your serial interface supports hardware handshaking, you should use it (set switch S5 to CLOSED). Hardware handshaking will make the serial connection much more reliable.

- 4 Set switches S6-S8 for the baud rate you will use. These switch settings are listed on the bottom of the emulation probe.

The higher baud rates may not work reliably with all hosts and user interfaces. Make sure the baud rate you choose is supported by your host and user interface.

Example

To use a baud rate of 9600 baud, set the switches as follows:

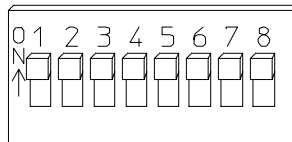

e3490b05

To connect a serial cable

CAUTION

Use a grounded, shielded cable. If the cable is not shielded, or if the cable is not grounded at the serial controller, the emulation probe may be damaged by electrostatic discharge.

Connect an RS-232C modem cable from the host computer to the emulation probe. The recommended cable is HP part number C2932A. This is a 9-pin cable with one-to-one pin connections.

Chapter 2: Connecting the Emulation Probe to a LAN Setting Up a Serial Connection

If you want to build your own RS-232 cable, follow the pinout shown in the following figure:

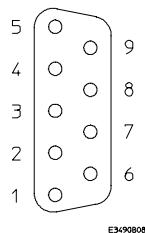

Serial Cable Pinout

Pin Number	Signal	Signal Description
1	DCD	Data Carrier Detect (not used)
2	TD	Transmit Data (data coming from Agilent Technologies emulation probe)
3	RD	Receive Data (data going to Agilent Technologies emulation probe)
4	DTR	Data Terminal Ready (not used)
5	GND	Signal Ground
6	DSR	Data Set Ready (Output from Agilent Technologies emulation probe)
7	RTS	Request to Send (Input to Agilent Technologies emulation probe)
8	CTS	Clear to Send (connected to pin 6)
9	RING	Ring Indicator (not used)

To verify serial communications

1 Start a terminal emulator program on the host computer.

If you are using a PC, the Terminal application in Microsoft Windows will work fine.

If you are using a UNIX workstation, you can use a terminal emulator such as `cu` or `kermit`.

2 Plug the power cord into the emulation probe.

When the emulation probe powers up, it sends a message (similar to the one that follows) to the serial port and then displays a prompt:

```
Copyright (c) Agilent Technologies 1987
All Rights Reserved.  Reproduction, adaptation, or translation without prior
written permission is prohibited, except as allowed under copyright laws.
```

```
E3499A Series Emulation System
Version:  A.07.06 06May97
Location: Generics
```

```
E3497A Motorola MPC800 PowerPC Emulator
Version:  A.02.04 28Jul97
```

R>

The version numbers may be different for your emulation probe.

3 Press the Return or Enter key a few times.

You should see a prompt such as "`p>`", "`C>`", or "`?>`".

For information about the commands you can use, enter `?` or `help` at the prompt.

See Also "Problems with the Serial Interface," page 129.

Installing the Emulation Module

Installing the Emulation Module

This chapter shows you how to install an emulation module in your Agilent Technologies 16600A/700A-series logic analysis system.

If your emulation module is already installed in your logic analysis system frame, you may skip this chapter.

Caution

These instructions are for trained service personnel. To avoid dangerous electric shock, do not perform any service unless qualified to do so. Do not attempt internal service or adjustment unless another person, capable of rendering first aid and resuscitation, is present.

Electrostatic discharge can damage electronic components. Use grounded wriststraps and mats when you handle modules.

To install the emulation module in a 16700A-series logic analysis system or a 16701A expansion frame

You will need T-10 and T-15 Torx screw drivers.

- 1** Turn off the logic analysis system and REMOVE THE POWER CORD.
Remove any other cables (such as probes, mouse, or video monitor).
- 2** Turn the logic analysis system frame upside-down.
- 3** Remove the bottom cover.

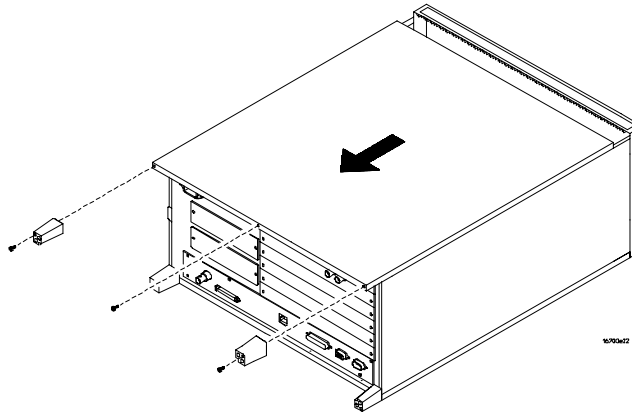

- 4** Remove the slot cover.
You may use either slot.

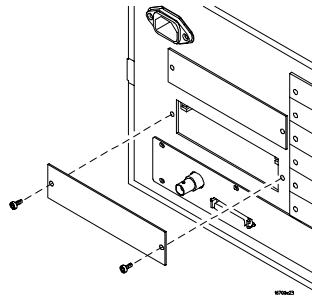

5 Install the emulation module.

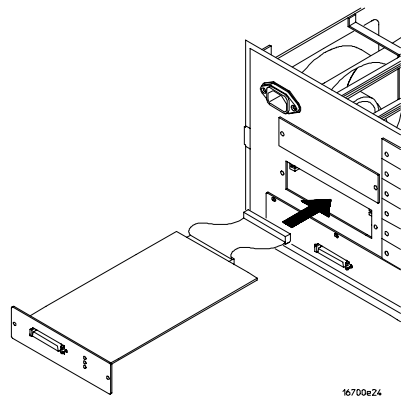

6 Connect the cable and re-install the screws.

You may connect the cable to either of the two connectors. If you have two emulation modules, note that many debuggers will work only with the "first" module: the one toward the top of the frame ("Slot 1"), plugged into the connector nearest the back of the frame.

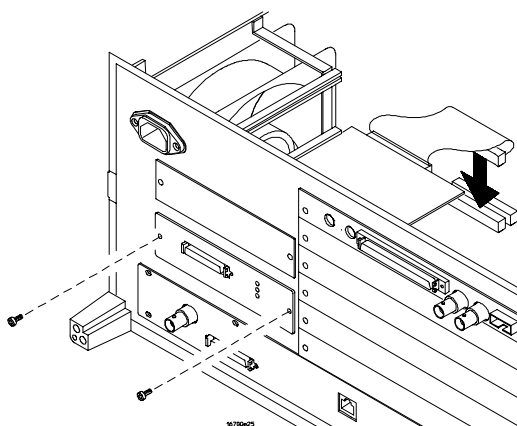

7 Reinstall the bottom cover, then turn the frame right-side-up.

8 Plug in the power cord, reconnect the other cables, and turn on the logic analysis system.

The new emulation module will be shown in the system window.

See Also

See page 107 for information on giving the emulation module a "personality" for your target processor.

To install the emulation module in a 16600A-series logic analysis system

You will need T-8, T-10, and T-15 Torx screw drivers.

- 1 Turn off the logic analysis system and REMOVE THE POWER CORD. Remove any other cables (such as probes, mouse, or video monitor).
- 2 Slide the cover back.

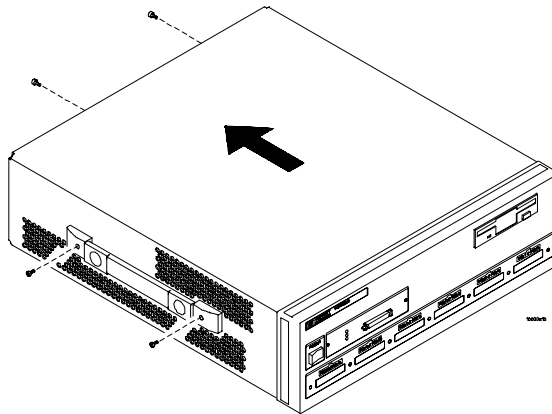

- 3 Remove the slot cover.

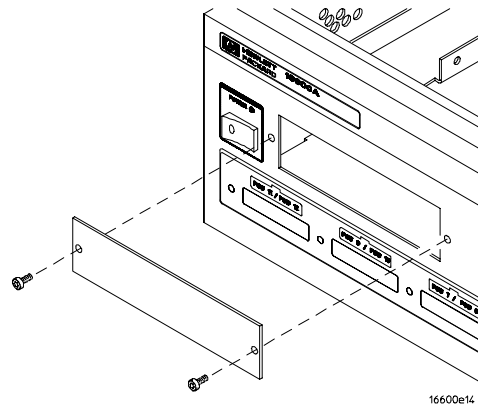

- 4 Install the emulation module.
- 5 Connect the cable and re-install the screws.

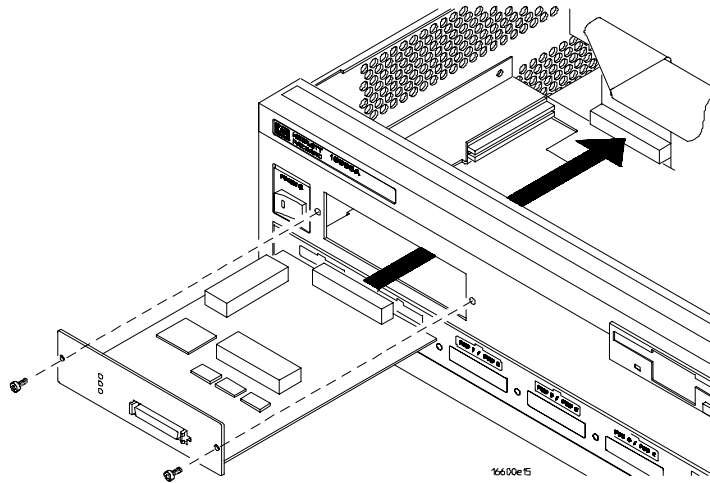

- 6 Reinstall the cover.
Tighten the screws snugly (2 N•m or 18 inch-pounds).
- 7 Plug in the power cord, reconnect the other cables, and turn on the logic analysis system.
The new emulation module will be shown in the system window.

See Also

See page 107 for information on giving the emulation module a "personality" for your target processor.

Installing Software on a 16600A/700A

Installing Software on a 16600A/700A

This chapter explains how to install the software you will need for your analysis probe or emulation solution.

Installing and loading

Installing the software will copy the files to the hard disk of your logic analysis system. Later, you will need to **load** some of the files into the appropriate hardware module.

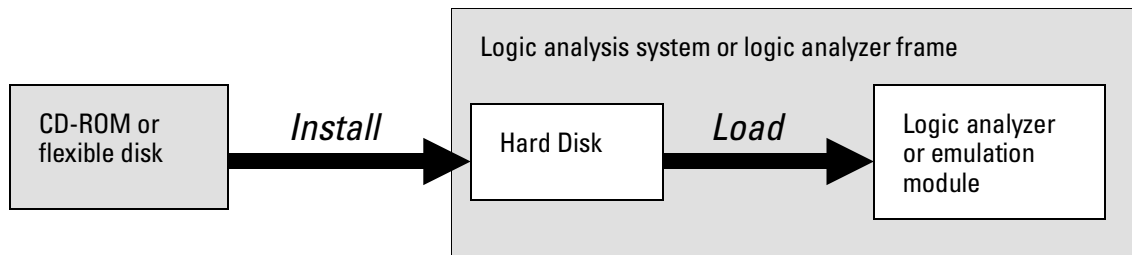

What needs to be installed

Agilent Technologies 16600A/700A-series logic analysis systems

If you ordered an emulation solution with your logic analysis system, the software was installed at the factory.

The following files are installed when you install a processor support package from the CD-ROM:

- Logic analysis system configuration files
- Inverse assembler (automatically loaded with the configuration files)
- Personality files for the Setup Assistant
- Emulation module firmware
- Emulation Control Interface

The Agilent Technologies B4620B Source Correlation Tool Set is installed with the logic analysis system's operating system.

To list software packages which are installed (16600A/700A)

- In the System Administration Tools window, click **List...**

To install the software from CD-ROM (16600A/700A)

Installing a processor support package from a CD-ROM will take just a few minutes. If the processor support package requires an update to the Agilent Technologies 16600A/700A operating system, installation may take approximately 15 minutes.

If the CD-ROM drive is not connected, see the instructions printed on the CD-ROM package.

1 Turn on the CD-ROM drive first and then turn on the logic analysis system.

2 Insert the CD-ROM in the drive.

3 Click the **System Admin icon.**

4 Click **Install...**

Change the media type to "CD-ROM" if necessary.

5 Click **Apply.**

6 From the list of types of packages, select "PROC-SUPPORT."

A list of the processor support packages on the CD-ROM will be displayed.

7 Click on the "MPC8XX" package.

If you are unsure if this is the correct package, click Details for information on what the package contains.

8 Click **Install...**

The dialog box will display "Progress: completed successfully" when the installation is complete.

9 Click **Close.**

The configuration files are stored in `/hplogic/configs/hp/processor`.

The inverse assemblers are stored in `/hplogic/ia`.

See Also

The instructions printed on the CD-ROM package for a summary of the installation instructions.

The online help for more information on installing, licensing, and removing software.

Connecting and Configuring the Emulator

Connecting and Configuring the Emulator

This chapter shows you how to connect the emulator to the target system and how to configure the emulator and target processor.

Overview

Here is a summary of the steps for connecting and configuring the emulator:

- 1** Make sure the target system is designed to work properly with the emulator. (Page 58.)
- 2** Install the emulation module in your logic analysis system, if necessary. (Page 43.)
If you are connecting an emulation module to an Agilent Technologies 16600A/700A-series logic analysis system, use the Setup Assistant to guide you through steps 3-6.
- 3** Connect the emulator to your target system using the 50-pin cable and the TIM or an analysis probe. (Page 61.)
- 4** Update the firmware of the emulator, if necessary. (Page 107.)
- 5** Verify communication between the emulator and the target.
- 6** Configure the emulator. (Page 64.)
- 7** Test the connection between the emulator and the target. (Page 78.)
- 8** Connect a debugger to the emulator, if applicable. (Page 81.)

See Also

"Using the Emulator with a Debugger" beginning on page 81 for information on configuring the emulator with a debugger, and for information on configuring LAN port numbers.

Using the Emulation Control Interface

The Emulation Control Interface in your Agilent Technologies 16600A/700A-series logic analysis system allows you to control an emulator (an emulation module or an emulation probe).

As you set up the emulator, you will use the Emulation Control Interface to:

- Update firmware (which reloads or changes the processor-specific personality of the emulator).
- Change the LAN port assignment (rarely necessary).
- Run performance verification tests on the emulator.

The Emulation Control Interface allows you to:

- Run, break, reset, and step the target processor.
- Set and clear breakpoints.
- Read and write registers.
- Read and write memory.
- Read and write I/O memory.
- View memory in mnemonic form.
- Read and write the emulator configuration.
- Download programs (in Motorola S-Record or Intel Hex format) to the target system RAM or ROM.
- View emulator status and errors.
- Write and play back emulator command script files .

If you have an emulation probe, this interface also allows you to configure the LAN address of the emulation probe.

Using the logic analysis system's intermodule bus does not require the Emulation Control Interface to be running. If the emulation module icon is in the Intermodule window, then it will be able to send and receive signals. Therefore if you are using a debugger, you can use an analyzer to cause a break.

Using a debugger with the Emulation Control Interface is not recommended because:

- The interfaces can get out of synchronization when commands are issued from both interfaces. This causes windows to be out-of-date and can cause confusion.
- Most debuggers cannot tolerate another interface issuing commands and may not start properly if another interface is running.

See Also

All of the Emulation Control Interface windows provide online help with a **Help** button or a **Help→On this window** menu selection. Refer to the online help for complete details about how to use a particular window.

To start the Emulation Control Interface from the main System window (emulation module)

- 1 In the System window, click the emulation module icon.
- 2 Select **Start Session...**

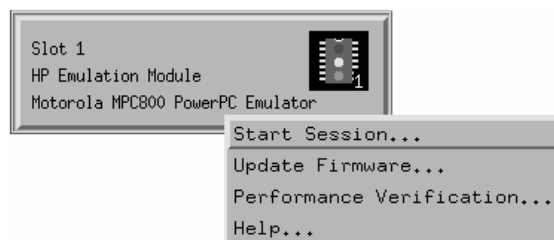

To start the Emulation Control Interface from the Workspace window (emulation module)

- 1 Open the Workspace window.
- 2 Drag the Emulator icon onto the workspace.
- 3 Right-click on the Emulator icon, then select **Start Session...**

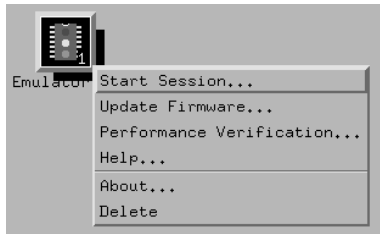

To start the Emulation Control Interface (emulation probe)

If you have a stand-alone emulation probe connected to the logic analysis system via LAN, use the Emulation Probe icon instead of the Emulator icon.

- 1 Open the Workspace window.
- 2 Drag the Emulation Probe icon onto the workspace.
- 3 Right-click on the Emulation Probe icon, then select **Start Session...**



- 4 In the Session window, enter the IP address or LAN name of the emulation probe, then click **Start Session**.

Designing a Target System for the Emulator

For your target system to work properly with the emulator, it must meet the following requirements:

- The DSDI and DSCK signals must not be actively driven by the target system when the debug port is being used.
- The $\overline{\text{HRESET}}$ and $\overline{\text{SRESET}}$ signals from the debug connector must be ORed with the $\overline{\text{HRESET}}$ and $\overline{\text{SRESET}}$ signals that connect to the processor on the target system. They can be logically ORed or "wire-ORed" on the board. Agilent Technologies recommends "wire-ORing" the signals so that the emulator can detect when the target is in reset. The emulator will drive $\overline{\text{HRESET}}$ and $\overline{\text{SRESET}}$ through a 100Ω resistor.

The emulator adds about 40 pF to all target system signals routed to the debug connector. This added capacitance may reduce the rise time of the $\overline{\text{SRESET}}$ or the $\overline{\text{HRESET}}$ signal beyond the processor specifications. If so, the target may need to increase the pull-up current on these signal lines.

Debug port connections

If you plan to connect the emulator directly to the target system, the target system should have a debug port (BDM) connector.

The connector should be a dual row header strip ("Berg connector"), 10 pins per inch, with 25 mil pins.

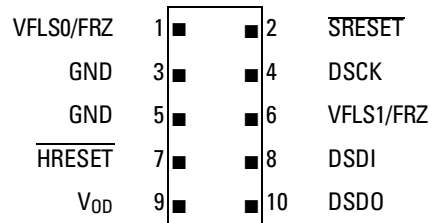

Pins 1 and 6 may be connected to VFLS0 and VFLS1 respectively, or, if a single freeze line is used, to the FRZ line.

Debug port signals

Header Pin Number	Signal Name	I/O	MPC860/ 821 Pin No. ¹	Board Resistor
1	VFLS0	Out	H2	
2	SRESET	In/Out	P2	10K Ω pullup
3	GND			
4	DSCK	In	H16	
5	GND			
6	VFLS1	Out	J3	
7	HRESET	In/Out	N4	10K Ω pullup
8	DSDI	In	H17	
9	3.3 v			
10	DSDO	In	G17	

¹ Pin numbers are for 357 BGA packages.

See Also

Chapter 18, "Development Support," of the Motorola *MPC860 User's Manual*.

Connecting the Emulator to the Target System

Choose one of the following methods for connecting the emulator to a target system.

- Directly through a debug port connector on the target board.
- Through an Agilent Technologies E2476A analysis probe, which provides a direct connection to the debug port pins.

After you have connected the emulator to your target system, you may need to update the firmware in the emulator.

See Also

For information on designing a debug port on your target board, see page 58.
For a list of the parts supplied with the emulator, see page 21.

To connect to a target system using a debug port

The emulator can be connected to a target system through a 10-pin debug port (BDM connector). The emulator should be connected to a 10-pin male 2x5 header connector on the target system using the 10-conductor cable assembly provided.

- 1 Turn off the target system and disconnect it from all power sources.
- 2 Plug one end of the 50-pin cable into the emulator.

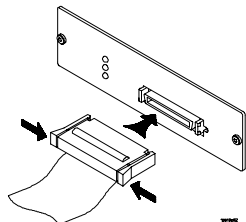

- 3 Plug the other end of the 50-pin cable into the target interface module.
- 4 Plug one end of the 10-pin cable into the target interface module.
- 5 Plug the other end of the 10-pin cable into the debug port on the target system.

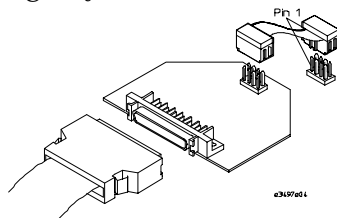

- 6 Turn on the power to the logic analysis system and then the target system.

See Also

"Designing a Target System" (page 58) for information on designing a target system for use with the emulator.

To connect to a target system using an analysis probe

- 1 Remove power from the target system.
- 2 Plug one end of the 50-pin cable into the emulator.
- 3 Plug the other end of the 50-pin cable into the connector on the analysis probe.

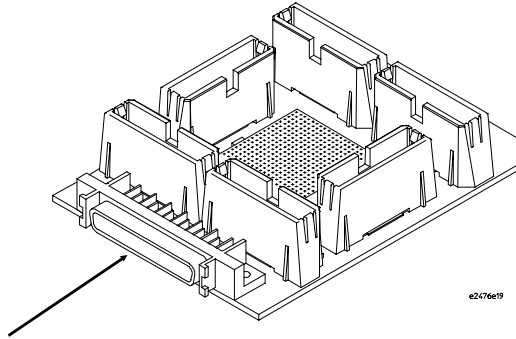

The 50-pin cable from the emulator plugs in here

Configuring the Emulator

The emulator has several user-configurable options. These options may be customized for specific target systems and saved in configuration files for future use.

The easiest way to configure the emulator is through the Emulation Control Interface in an Agilent Technologies 16600A or 16700A logic analysis system.

If you use the Emulation Control Interface, please refer to the online help in the Configuration window for information on each of the configuration options.

Other ways to configure the emulator are by using:

- the emulator's built-in terminal interface
- your debugger, if it provides an "emulator configuration" window which can be used with this Agilent Technologies emulator

What can be configured

The following options can be configured using the Emulation Control Interface or using built-in commands:

- Processor type.
- Processor clock speed.
- Default reset level.
- "Break In" type.
- BNC break in behavior. (Emulation probe only)
- BNC trigger out behavior. (Emulation probe only)
- The emulator's copy of the IMMR register.
- The emulator's copy of the SYPCR register.
- The emulator's copy of the DER register.
- The emulator's copies of other internal registers.

You may need to set up the emulator copies of the target processor registers. If you have a boot ROM that initializes these registers, you don't need to configure these registers because you can simply run the boot ROM. If you do not have a boot ROM, then you will need to initialize these registers so that you can communicate with the memory of the processor. Once these register copies are defined, then every reset followed by a break will write the emulator copies of the configuration registers to the processor.

Once you have configured the register copies, it is a good idea to save a configuration. Loading the configuration will restore the values of all configuration options, including the register copies.

The default values for the other options will allow the emulator to work with most target systems.

The following option can be configured using built-in commands:

- Restriction to real-time runs.

The built-in "help cf" command also lists the following options, which are provided only for compatibility with standalone emulation probes:

To configure using the Emulation Control Interface

The easiest way to configure the emulator is to use the Emulation Control Interface.

1 Start an Emulation Control Interface session.

For an emulation module:

- In the system window, click the Emulation Control Interface icon, and then select "Start Session...".

For an emulation probe:

- In the workspace window, drag the emulation probe icon onto the workspace, then select "Start Session...".

2 Open a Configuration window.

Select "Configuration..." from the Emulation Control Interface icon or from the Navigate menu in any Emulation Control Interface window.

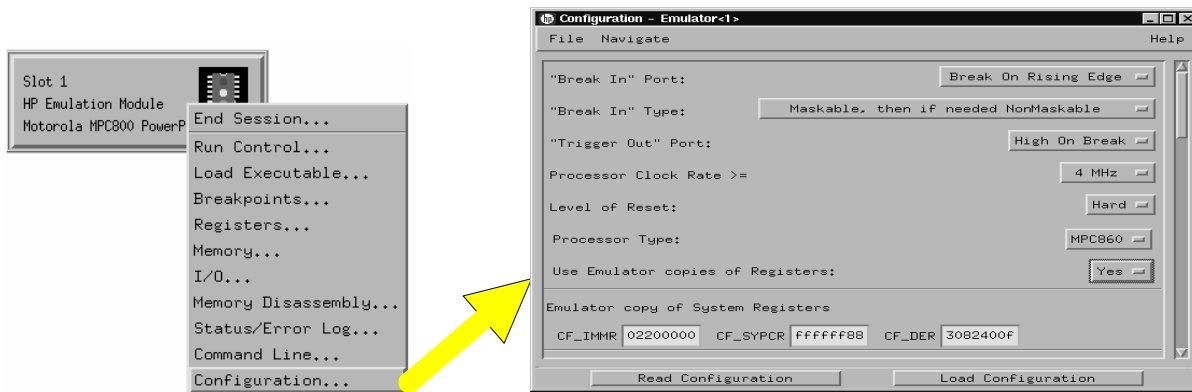

3 Set the configuration options, as needed.

The configuration selections will take effect when you close the configuration window or when you move the mouse pointer outside the window.

4 Save the configuration settings.

To save the configuration settings, open the File Manager window and click **Save...**

See Also **Help** → **Help on this window** in the Configuration window for information on each of the configuration options.
Help in the Emulation Control Interface menu for help on starting an Emulation Control session.

To configure using the built-in commands

If you are unable to configure the emulator with the Emulation Control Interface or a debugger interface, you can configure the emulator using the built-in "terminal interface" commands.

1 Connect a telnet session to the emulator over the LAN.

For example, on a UNIX system, for an emulation module in Slot 1 enter:

```
telnet LAN_address 6472
```

2 Enter `cf` to see the current configuration settings.

3 Use the `cf` command to change the configuration settings.

See Also Enter `help cf` for help on the configuration commands.

For information on connecting using telnet, and for information on other built-in commands, see page 123.

Example To see a complete list of configuration items, type "help cf". This command displays:

```
cf - display or set emulation configuration

cf                - display current settings for all config items
cf <item>         - display current setting for specified <item>
cf <item>=<value> - set new <value> for specified <item>
cf <item> <item>=<value> <item> - set and display can be combined

help cf <item>    - display long help for specified <item>

--- VALID CONFIGURATION <item> NAMES ---

proc             - Set type of target processor
procck          - Set clock speed of target processor
dprocck         - Display default clock speed of target processor
bnchardbrk      - Set BNC break type
breakin         - BNC break in control
cfreg           - Config Register Enable
```

```
fastdnld - Silicon fast download status
reset    - Set level of 'rst' command
rrt      - Set restriction to real time runs
trigout  - Trigger out control
```

M>

To configure using a debugger

Because the Agilent Technologies emulator can be used with several third-party debuggers, specific details for sending the configuration commands from the debugger to the emulator cannot be given here. However, all debuggers should provide a way of directly entering terminal mode commands to the emulator. Ideally, you would create a file that contains the modified configuration entries to be sent to the emulator at the beginning of each debugger session.

See Also

Information about specific debuggers in the "Using the Emulator with a Debugger" chapter (page 81).

Your debugger manual.

To configure the processor type

If you are using an MPC821, you need to set the PowerPC processor type.

Processor type configuration

Value	Emulator configured for	Built-in command
MPC860	MPC860 (Default)	<code>cf proc=MPC860</code>
MPC850	MPC850	<code>cf proc=MPC850</code>
MPC821	MPC821	<code>cf proc=MPC821</code>
MPC801	MPC801	<code>cf proc=MPC801</code>

The `cf save -s` command will store the processor type configuration in the emulator's flash memory. The `cf save -r` command will restore this configuration.

To configure the processor clock speed

The BDM communication speed will be 1/3 of the configured processor clock speed. You may set the processor clock speed to a speed lower than the actual clock speed of your target system. Use the 25 MHz option for microprocessors running faster than 25 MHz.

Processor clock speed configuration

Value	Processor clock is at least	Built-in command
25	25 MHz	<code>cf procck=25</code>
20	20 MHz	<code>cf procck=20</code>
16	16 MHz	<code>cf procck=16</code>
8	8 MHz	<code>cf procck=8</code>
4	4 MHz (default)	<code>cf procck=4</code>
1	1 MHz	<code>cf procck=1</code>
512	512 kHz	<code>cf procck=512</code>
32	32 kHz	<code>cf procck=32</code>

You can also set the reset clock speed, which controls the BDM communication speed used after a reset, but before the Multiplication Factor in the SCCR is set up:

Reset processor clock speed configuration

Value	Processor clock is at least	Built-in command
25	25 MHz	<code>cf dprocck=25</code>
4	4 MHz	<code>cf dprocck=4</code>
32	32 kHz	<code>cf dprocck=32</code>

To configure restriction to real-time runs

Real-time runs configuration

Value	Emulator configuration	Built-in command
no	Allows commands which break to the monitor. Examples include commands which display memory or registers. (Default)	<code>cf rrt=no</code>
yes	No commands are allowed which break to the monitor, except "break," "reset," "run," or "step."	<code>cf rrt=yes</code>

To configure the default reset level

Reset level configuration

Value	The "reset" command will	Built-in command
hard	Cause a hard reset (Default)	<code>cf reset=hard</code>
soft	Cause a soft reset	<code>cf reset=soft</code>

To view the download speed

Download speed is automatically determined. The `cf fastdnld` command displays the download speed configuration.

Download speed configuration

Value	Meaning	Built-in command
yes	On-chip acceleration logic is functional.	<code>cf fastdnld</code>
no	On-chip logic is not functioning correctly. You are using one of the older processor revisions which had a bug in the fast download logic.	

To configure the "Break In" type

This option affects how the emulator will react to a trigger in an intermodule measurement.

"Break In" type configuration

Value	What happens when the emulator is triggered
Maskable	A trigger will immediately cause a maskable break. If the maskable break fails, a non-maskable break will be attempted. The delay between an attempted maskable break and the non-maskable break will allow many instructions to be executed. (Default)
NonMaskable	A trigger will immediately cause a non-maskable break. Use this value if you are trying to halt the processor in an ISR. The processor may not be able to continue running after the break.

To configure the Trigger Out BNC (Emulation Probe Only)

With an emulation module, this configuration item is always set to the default setting and cannot be changed with a `cf` command. The Intermodule window of the logic analysis system must be used instead.

Trigger out configuration

Value	The Trigger Out BNC will	Built-in command
fixhigh	Always be high	<code>cf trigout=fixhigh</code>
fixlow	Always be low	<code>cf trigout=fixlow</code>
monhigh	Go high when the processor is running in background (Default)	<code>cf trigout=monhigh</code>
monlow	Go low when the processor is running in background	<code>cf trigout=monlow</code>

To configure the Trigger In BNC (Emulation Probe Only)

With an emulation module, this configuration item is always set to the default setting and cannot be changed with a `cf` command. The Intermodule window of the logic analysis system must be used instead.

Trigger in configuration

Value	Meaning	Built-in command
off	Inputs to the Break In BNC will be ignored.	<code>cf breakin=off</code>
rising	The emulation probe will cause a break on a rising edge. (Default)	<code>cf breakin=rising</code>
falling	The emulation probe will cause a break on a falling edge.	<code>cf breakin=falling</code>

To configure the emulator's copy of the IMMR register

The IMMR register specifies the location of memory-mapped registers.

To set the emulator's copy of the IMMR register using the built-in terminal interface, use the `reg cf_immr=value` command. Use a 32-bit hexadecimal value. Only the upper 16 bits are programmed into the IMMR—the lower 16 bits are read-only.

After a break from reset, the processor is programmed with the value from the emulator's copy.

To display the value of the emulator's copy using the built-in terminal interface, use the `reg cf_immr` command.

To configure the emulator's copy of the SYPCR register

The processor's SYPCR register is automatically programmed from the emulator's copy after a break from reset.

To set the emulator's copy of the SYPCR register using the built-in terminal interface, use the `reg cf_sypcr=value` command. Use a 32-bit hexadecimal value. The value you enter will be OR'ed with 0x00000080 to ensure that the watchdog timer is disabled in background.

To display the value of the emulator's copy using the built-in terminal interface, use the `reg cf_sypcr` command.

To configure the emulator's copy of the DER register

The DER register (debug enable register) controls which exceptions cause the processor to enter debug mode. The processor's DER register is automatically programmed from the emulator's copy after a break from reset.

To set the emulator's copy of the DER register using the built-in terminal interface, use the `reg cf_der=value` command.

To display the value of the emulator's copy using the built-in terminal interface, use the `reg cf_der` command.

The default value for this register is 0x3082400f.

To disable configuration registers

By default, the emulator's copies of the memory-mapped registers and the IMMR, SYPCR, and DER registers are automatically programmed into the processor after a break from reset. You can disable this automatic initialization using the `cfreg` command.

Configuration register initialization

Value	Meaning	Built-in command
yes	Automatic register initialization is enabled. The processor probe's copies will be used to initialize the target. (Default)	<code>cfreg=yes</code>
no	Automatic register initialization is disabled. The values in the emulator's copies of the configuration registers will be ignored.	<code>cfreg=no</code>

To configure a Motorola 860ADS target system

- Create an initialization file for your debugger or for the Emulation Control Interface.

The sample initialization file performs the following tasks:

- Disabling the watch-dog timer
- Maximizing the clock multiplier, and maximizing the debug clock for efficient download
- Programming the UPM registers
- Programming the chip selects

The initialization commands to do the above should be run after every reset; break that is done (because the reset will disrupt many of the register values).

```
# Configuration File for the Motorola MPC860 ADS Board
#
# This file will program the memory system after a
# target reset has occurred.

reg immr=ff000000          # Memory mapped registers
                           # base address

reg msr=1002

m -a4 -d4 0@reg=01612440   # SIUMCR
m -a4 -d4 4@reg=ffffff88   # SYPCR (disable watch-dog
                           # timer)

m -a4 -d4 284@reg=0x00500000 # PLPRCR - Maximize the clock
                           # multiplier
cf procck=25              # Maximize the debug clock
                           # for download

# Configure the UPM
m -a4 -d4 0@upm=0fffcc24   # Single Read
m -a4 -d4 4@upm=0fffcc04
m -a4 -d4 8@upm=0cffcc04
m -a4 -d4 c@upm=00ffcc04
m -a4 -d4 10@upm=00ffcc00
m -a4 -d4 14@upm=37ffcc47
m -a4 -d4 18@upm=fffffff
m -a4 -d4 1c@upm=fffffff
```

Chapter 5: Connecting and Configuring the Emulator

Configuring the Emulator

```
m -a4 -d4 20@upm=0fffcc24 # Burst Read
m -a4 -d4 24@upm=0fffcc04
m -a4 -d4 28@upm=08ffcc04
m -a4 -d4 2c@upm=00ffcc04
m -a4 -d4 30@upm=00ffcc08
m -a4 -d4 34@upm=0cffcc44
m -a4 -d4 38@upm=00ffec0c
m -a4 -d4 3c@upm=03ffec00
m -a4 -d4 40@upm=00ffec44
m -a4 -d4 44@upm=00ffcc08
m -a4 -d4 48@upm=0cffcc44
m -a4 -d4 4c@upm=00ffec04
m -a4 -d4 50@upm=00ffec00
m -a4 -d4 54@upm=3fffec47
m -a4 -d4 58@upm=ffffffff
m -a4 -d4 5c@upm=ffffffff
m -a4 -d4 60@upm=0fafcc24 # Single Write
m -a4 -d4 64@upm=0fafcc04
m -a4 -d4 68@upm=08afcc04
m -a4 -d4 6c@upm=00afcc00
m -a4 -d4 70@upm=37ffcc47
m -a4 -d4 74@upm=ffffffff
m -a4 -d4 78@upm=ffffffff
m -a4 -d4 7c@upm=ffffffff

m -a4 -d4 80@upm=0fafcc24 # Burst Write
m -a4 -d4 84@upm=0fafcc04
m -a4 -d4 88@upm=08afcc00
m -a4 -d4 8c@upm=07afcc4c
m -a4 -d4 90@upm=08afcc00
m -a4 -d4 94@upm=07afcc4c
m -a4 -d4 98@upm=08afcc00
m -a4 -d4 9c@upm=07afcc4c
m -a4 -d4 a0@upm=08afcc00
m -a4 -d4 a4@upm=37afcc47
m -a4 -d4 a8@upm=ffffffff
m -a4 -d4 ac@upm=ffffffff
m -a4 -d4 b0@upm=ffffffff
m -a4 -d4 b4@upm=ffffffff
m -a4 -d4 b8@upm=ffffffff
m -a4 -d4 bc@upm=ffffffff
m -a4 -d4 c0@upm=e0ffcc84 # Refresh
m -a4 -d4 c4@upm=00ffcc04
m -a4 -d4 c8@upm=00ffcc04
m -a4 -d4 cc@upm=0fffcc04
```

```
m -a4 -d4 d0@upm=7ffffc04
m -a4 -d4 d4@upm=ffffcc86
m -a4 -d4 d8@upm=ffffcc05
m -a4 -d4 dc@upm=ffffffff
m -a4 -d4 e0@upm=ffffffff
m -a4 -d4 e4@upm=ffffffff
m -a4 -d4 e8@upm=ffffffff
m -a4 -d4 ec@upm=ffffffff

m -a4 -d4 f0@upm=33ffcc07 # Exception
m -a4 -d4 f4@upm=ffffffff
m -a4 -d4 f8@upm=ffffffff
m -a4 -d4 fc@upm=40004650
# Program the Chip Selects for the following memory map
# 0..400000 - DRAM
# 2100000.. - ADS Board Registers
# 2800000..2900000 - Flash
# ff00000 - CPU

m -a4 -d4 100@reg=02800001 # BR0 - Flash
m -a4 -d4 104@reg=ffe00d34 # OR0
m -a4 -d4 108@reg=02100001 # BR1 - ADS Registers
m -a4 -d4 10c@reg=ffff8110 # OR1
m -a4 -d4 110@reg=00000081 # BR2 - DRAM
m -a4 -d4 114@reg=ffc00800 # OR2

m -a2 -d2 17a@reg=0400
m -a4 -d4 170@reg=9ca21114

m -a2 -d2 200@reg=00c2
m -a2 -d2 240@reg=0082

reg srr1=1002
reg der=ffe7400f
```

Testing the emulator and target system

After you have connected and configured the emulator, you should perform some simple tests to verify that everything is working.

See Also

"Troubleshooting the Emulator" on page 117 for information on testing the emulator hardware.

To test memory accesses

- 1 Start the Emulation Control Interface and configure the emulator, if necessary.
- 2 Open the Memory window.
- 3 Write individual locations or fill blocks of memory with patterns of your choosing.

The access size is the size of memory access that will be used to write or read the memory values.

- 4 Use the Memory I/O window to stimulate I/O locations by reading and writing individual memory locations.

To test with a running program

To more fully test your target, you can load simple programs and execute them.

- 1 Compile or assemble a small program and store it in a Motorola S-Record or Intel Hex file.
- 2 Use the Load Executable window to download the program into RAM or flash memory.

- 3** Use the **Breakpoints** window to set breakpoints. Use the **Registers** window to initialize register values.

The new register or breakpoint values are sent to the processor when you press the Enter key or when you move the cursor out of the selected register field.

- 4** In the **Run Control** window, click **Run**.
- 5** Use the **Memory Mnemonic** window to view the program and use the **Memory** window to view any output which has been written to memory.

Using the Emulator with a Debugger

Using the Emulator with a Debugger

Several prominent companies design and sell state-of-the-art source debuggers which work with the Agilent Technologies emulation module and emulation probe.

Benefits of using a debugger

The debugger will enable you to control the execution of your processor from the familiar environment of your debugger. Using a debugger lets you step through your code at the source-code level.

With a debugger connection, you can set breakpoints, single-step through source code, examine variables, and modify source code variables from the debugger interface. The debugger can also be used to download executable code to your target system.

Using a debugger to connect the emulator allows the entire design team to have a consistent interface from software development to hardware/software integration.

Debugger interfaces must be ordered directly from the debugger vendor.

Compatibility with other logic analysis system tools

You can use your logic analysis system to collect and analyze trace data while you use your debugger. If you are using an X windows workstation or a PC with an X terminal emulator, you can display the logic analyzer windows right next to your debugger.

Here is an example of what the display on your PC or workstation might look like:

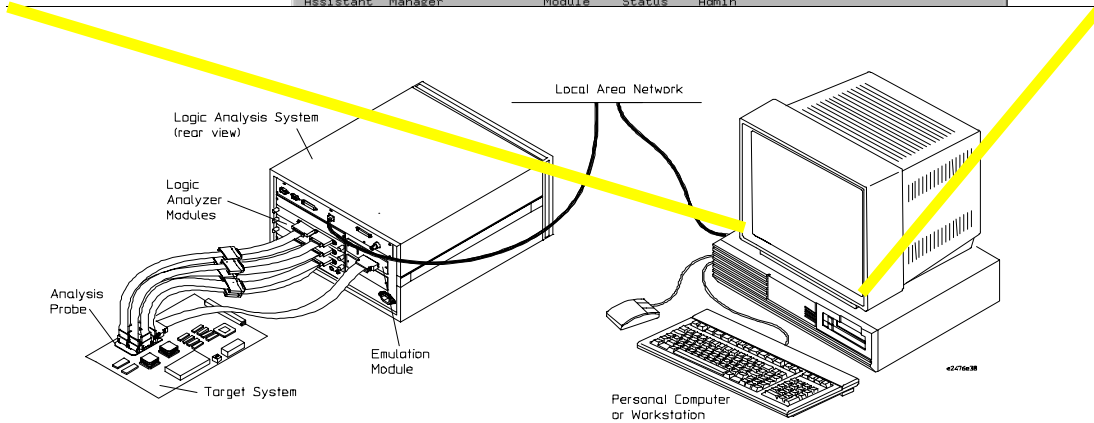
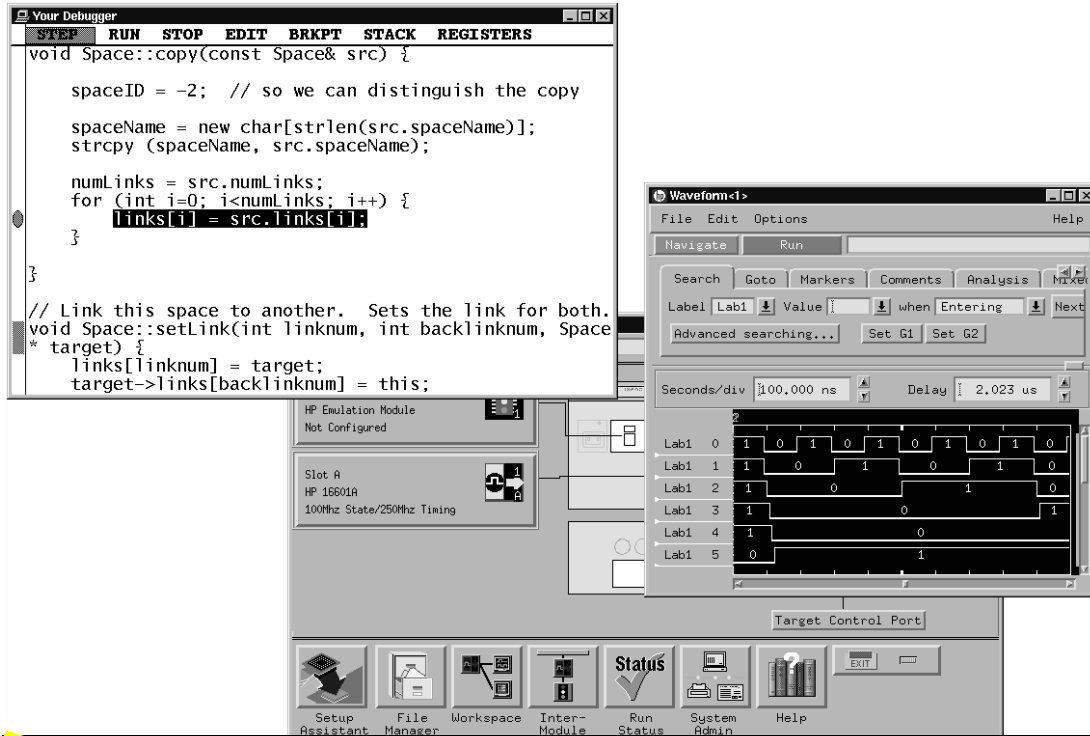

Minimum requirements

To use a debugger with the emulator, you will need:

- A debugger which is compatible with the emulator
- A LAN connection between the PC or workstation that is running the debugger, and the Agilent Technologies 16600A or 16700A logic analysis system
- X windows or an X terminal emulator, such as Reflection X on a PC. This is required only if you wish to have the logic analysis system user interface displayed on your PC or workstation screen, along with the debugger.

Is your debugger compatible with the emulator?

Ask your debugger vendor whether the debugger can be used with an Agilent Technologies emulation module or Agilent Technologies emulation probe (also known as a "processor probe" or "software probe").

LAN connection

You will use a LAN connection to allow the debugger to communicate with the emulator.

Compatibility with the Emulation Control Interface

Do not use the logic analysis system's Emulation Control Interface and your debugger at the same time.

Setting up Debugger Software

The instructions in this manual assume that your PC or workstation is already connected to the LAN, and that you have already installed the debugger software according to the debugger vendor's documentation.

To use your debugger with the emulator, follow these general steps:

- Connect the emulator to your target system (page 44).
- Connect the logic analysis system to the LAN (page 86).
- Export the logic analysis system's display to your PC or workstation (page 89).
- Configure the emulator (page 64).
- Begin using your debugger.

If you use the Emulation Control Interface to configure the emulator, remember to end the Emulation Control Interface session before you start the debugger.

Caution

Do not use the Emulation Control Interface at the same time as a debugger.

The Emulation Control Interface and debuggers do not keep track of commands issued by other tools. If you use both at the same time, the tools may display incorrect information about the state of the processor, possibly resulting in lost data.

See Also

Refer to the documentation for your debugger for more information on connecting the debugger to the emulator.

To connect the logic analysis system to the LAN

Information on setting up a LAN connection is provided in the online help or installation manual for your logic analysis system.

Your debugger will require some information about the LAN connection before it can connect to the emulator. This information may include:

- IP address (Internet address) or LAN name of the logic analysis system.
- Gateway address of the logic analysis system.
- Port number of the emulator.

Port numbers for emulators

Port number	Use for
Debugger connections	
6470	Slot 1 (First emulation module in an Agilent Technologies 16600A/700A-series logic analysis system) or emulation probe
6474	Slot 2 (Second emulation module in an Agilent Technologies 16700A-series system)
6478	Slot 3 (Third emulation module in an expansion frame)
6482	Slot 4 (Fourth emulation module in an expansion frame)
Telnet connections	
23	Emulation probe (standard telnet port number)
6472	Slot 1 (First emulation module)
6476	Slot 2 (Second emulation module)
6480	Slot 3 (Third emulation module)
6484	Slot 4 (Fourth emulation module)

Write the information here for future reference:

IP Address of Logic Analysis System _____

LAN Name of Logic Analysis System _____

Gateway Address _____

Port Number of Emulation Module _____

To change the port number of an emulator

Some debuggers do not provide a means to specify a port number. In that case, the debugger will always connect to port 6470 (the first emulation module). If you need to connect to another module, or if the port number of the first module has been changed, you must change the port number to be 6470.

The new port number must not be 0-1000 and must not already be assigned to another emulation module.

To view or change the port number using the Emulation Control Interface:

- 1 Click on the emulation module icon in the system window of the logic analysis system, then select **Update Firmware**.
- 2 Select **Modify Lan Port....**
- 3 If necessary, enter the new port number in the **Lan Port Address** field.
- 4 For an emulation probe, cycle power on the emulation probe.

To change the port number using built-in commands:

- 1 telnet to the IP address of the emulation module.

For example, on a UNIX system, enter "telnet <IP_address>".

- 2 Enter the "lan -p" command:

```
lan -p <new port number>
```

- 3 For an emulation probe, cycle power on the emulation probe.

To verify communication with the emulator

1 telnet to the IP address.

For example, on a UNIX system, enter "telnet <IP_address> 6472". This connection will give you access to the emulator's built-in terminal interface. You should see a prompt, such as "M>".

2 At the prompt, type:

```
ver
```

You should then see information about the emulator and firmware version.

3 To exit from this telnet session, type <CTRL>D at the prompt.

See Also

The online help or manual for your logic analysis system, for information on physically connecting the system to the LAN and configuring LAN parameters.

"Troubleshooting," page 126, if you have problems verifying LAN communication.

To export the logic analysis system's display to a workstation

By exporting the logic analyzer's display, you can see and use the logic analysis system's windows on the screen of your workstation. To do this, you must have telnet software and X windows installed on your computer.

- 1 On the workstation, add the host name of the logic analysis system to the list of systems allowed to make connections:

```
xhost +<IP_address>
```

- 2 Use **telnet** to connect to the logic analysis system.

```
telnet <IP_address>
```

- 3 Log in as "hplogic".

The logic analysis system will open a Session Manager window on your display.

- 4 In the Session Manager window, click **Start Session on This Display**.

Example

On a UNIX workstation, you could use the following commands to export the display of a logic analysis system named "mylogic":

```
$ xhost +mylogic
$ telnet mylogic
Trying...
Connected to mylogic.mycompany.com.
Escape character is '^]'.
Local flow control on
Telnet TERMINAL-SPEED option ON

Agilent Technologies Logic Analysis System

Please Log in as: hplogic [displayname:0]

login: hplogic
Connection closed by foreign host.
$
```

To export the logic analysis system's display to a PC

By exporting the logic analyzer's display, you can see and use the logic analysis system's windows on the screen of your PC . To do this, you must have telnet software and an X terminal emulator installed on your computer. The following instructions use the Reflection X emulator from WRQ, running on Windows 95, as an example.

1 On the PC, start the X terminal emulator software.

To start Reflection X, click the Reflection X Client Startup icon.

2 Start a telnet connection to the logic analysis system.

Log in as "hplogic".

For Reflection X, enter the following values in the Reflection X Client Startup dialog:

- a** In the Host field, enter the LAN name or IP address of the logic analysis system.
- b** In the User Name field, enter "hplogic".
- c** Leave the Password field blank.
- d** Leave the Command field blank.
- e** Click Run to start the connection.

The logic analysis system will open a Session Manager window on your display.

3 In the Session Manager window, click **Start Session on This Display.**

Using the Analysis Probe and Emulation Module Together

Using the Analysis Probe and Emulation Module Together

This chapter describes how to use an analysis probe, an emulation module, and other features of your Agilent Technologies 16600A or 16700A logic analysis system to gain insight into your target system.

What are some of the tools I can use?

You can use a combination of all of the following tools to control and measure the behavior of your target system:

- Your analysis probe, to acquire data from the processor bus while it is running full-speed.
- Your emulation module, to control the execution of your target processor and to examine the state of the processor and of the target system.
- The Emulation Control Interface, to control and configure the emulation module, and to display or change target registers and memory.
- Display tools including the Listing tool, Chart tool, and System Performance Analyzer tool to make sense of the data collected using the analysis probe.
- Your debugger, to control your target system using the emulation module. Do not use the debugger at the same time as the Emulation Control Interface.
- The Agilent Technologies B4620B Source Correlation Tool Set, to relate the analysis trace to your high-level source code.

Which assembly-level listing should I use?

Several windows display assembly language instructions. Be careful to use to the correct window for your purposes:

- The Listing tool shows processor states that were captured during a "Run" of the logic analyzer. Those states are disassembled and displayed in the Listing window.
- The Emulation Control Interface shows the disassembled contents of a section of memory in the Memory Disassembly window.
- Your debugger shows your program as it was actually assembled, and (if it supports the emulation module) shows which line of assembly code corresponds to the value of the program counter on your target system.

Which source-level listing should I use?

Different tools display source code for different uses:

- The Source Viewer window allows you to follow how the processor executed code as the analyzer captured a trace. Use the Source Viewer to set analyzer triggers. The Source Viewer window is available only if you have licensed the Agilent Technologies B4620B Source Correlation Tool Set.
- Your debugger shows which line of code corresponds to the current value of the program counter on your target system. Use your debugger to set breakpoints.

Where can I find practical examples of measurements?

The Measurement Examples section in the online help contains examples of measurements which will save you time throughout the phases of system development: hardware turn-on, firmware development, software development, and system integration.

A few of the many things you can learn from the measurement examples are:

- How to find glitches.
- How to find NULL pointer de-references.
- How to profile system performance.

To find the measurement examples, click on the Help icon in the logic analysis system window, then click on "Measurement Examples."

Triggering the Emulation Module from the Analyzer

You can trigger the emulation module from the logic analyzer using either the Source Viewer window or the Intermodule window. If you are using the Agilent Technologies B4620B Source Correlation Tool Set, using the Source Viewer window is the easiest method.

To stop the processor when the logic analyzer triggers on a line of source code (Source Viewer window)

If you have the Agilent Technologies B4620B Source Correlation Tool Set, you can easily stop the processor when a particular line of code is reached.

- 1 In the Source window, click on the line of source code where you want to set the trigger, then select **Trace about this line**.

The logic analyzer trigger is now set.

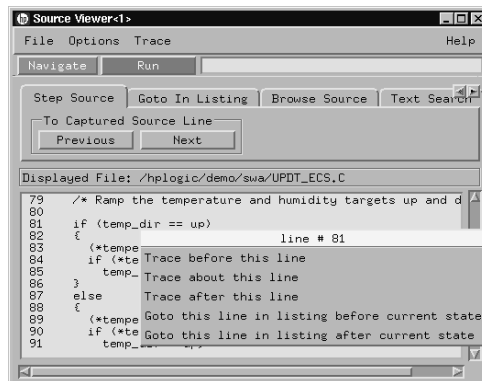

- 2 Select **Trace→Enable - Break Emulator On Trigger**.

The emulation module is now set to halt the processor after receiving a trigger from the logic analyzer.

To disable the processor stop on trigger, select **Trace→Disable - Break Emulator On Trigger**.

- 3 Click **Group Run** in the Source window (or other logic analyzer window).
- 4 If your target system is not already running, click **Run** in the emulation Run Control window to start your target.

To stop the processor when the logic analyzer triggers (Intermodule window)

Use the Intermodule window if you do not have the Agilent Technologies B4620B Source Correlation Tool Set or if you need to use a more sophisticated trigger than is possible in the Source Viewer window.

- 1 Create a logic analyzer trigger.
- 2 In the Intermodule window, click the emulation module icon, then select the analyzer which is intended to trigger it.

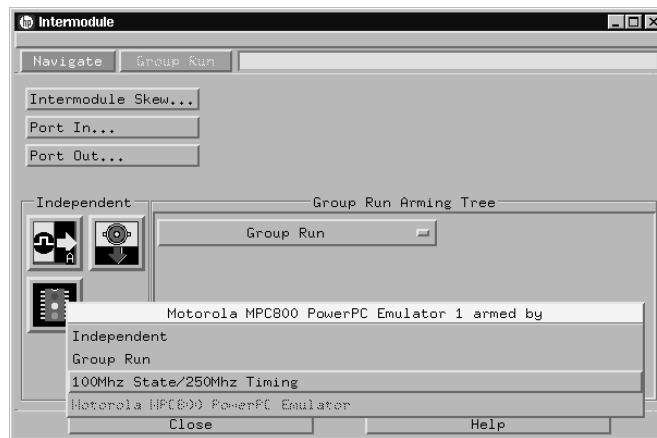

The emulation module is now set to stop the processor when the logic analyzer triggers.

- 3 Click **Group Run** in the Source window (or other logic analyzer window).
- 4 If your target system is not already running, click **Run** in the emulation Run Control window to start your target.

See Also

See the online help for your logic analysis system for more information on setting triggers.

To minimize the "skid" effect

There is a finite amount of time between when the logic analyzer triggers, and when the processor actually stops. During this time, the processor will continue to execute instructions. This latency is referred to as the skid effect.

To minimize the skid effect:

- 1 In the Emulation Control Interface, open the Configuration window.
- 2 Set processor clock speed to the maximum value which your target can support.

The amount of skid will depend on the processor's execution speed and whether code is executing from the cache. See page 69 for information on how to configure the clock speed.

To stop the analyzer and view a measurement

- To view an analysis measurement you may have to click **Stop** after the trigger occurs.

When the target processor stops it may cause the analyzer qualified clock to stop. Therefore most intermodule measurements will have to be stopped to see the measurement.

Example

An intermodule measurement has been set up where the analyzer is triggering the emulation module. The following sequence could occur:

- 1 The analyzer triggers.
- 2 The trigger ("Break In") is sent to the emulation module.
- 3 The emulation module stops the user program which is running on the target processor. The processor enters a background debug monitor.
- 4 Because the processor has stopped, the analyzer stops receiving a qualified clock signal.
- 5 If the trigger position is "End", the measurement will be completed. If the trigger position is not "End", the analyzer may continue waiting for more states.
- 6 The user clicks **Stop** in a logic analyzer window, which tells the logic analyzer to stop waiting, and to display the trace.

Tracing until the processor halts

If you are using a state analyzer, you can begin a trace, run the processor, then manually end the trace when the processor has halted.

To halt the processor, you can set a breakpoint using the Emulation Control Interface or a debugger.

Some possible uses for this measurement are:

- To store and display processor bus activity leading up to a system crash.
- To capture processor activity before a breakpoint.
- To determine why a function is being called. To do this, you could set a breakpoint at the start of the function then use this measurement to see how the function is getting called.

This kind of measurement is easier than setting up an intermodule measurement trigger.

To capture a trace before the processor halts

- 1 Set the logic analyzer to trigger on **nostate**.
- 2 Set the trigger point (position) to **End**.
- 3 In a logic analyzer window, click **Run**.
- 4 In the Emulation Control Interface or debugger click **Run**.
- 5 When the emulation module halts click **Stop** in the logic analyzer window to complete the measurement.

This is the recommended method to do state analysis of the processor bus when the processor halts.

If you need to capture the interaction of another bus when the processor halts or you need to make a timing or oscilloscope measurement you will need to trigger the logic analyzer from the emulation module (described in the next section).

Triggering the Logic Analyzer from the Emulation Module

You can create an intermodule measurement which will allow the emulation module to trigger another module such as a timing analyzer or oscilloscope.

If you are only using a state analyzer to capture the processor bus then it will be much simpler to use "Tracing until processor halts" as described on page 98.

Before you trigger a logic analyzer (or another module) from the emulation module, you should understand a few things about the emulation module trigger:

The emulation module trigger signal

The trigger signal coming from the emulation module is an "In Background Debug Monitor" ("In Monitor") signal. This may cause confusion because a variety of conditions could cause this signal and falsely trigger your analyzer.

The "In Monitor" trigger signal can be caused by:

- The most common method to generate the signal is to click **Run** and then click **Break** in the Emulation Control Interface. Going from "Run" (Running User Program) to "Break" ("In Monitor") generates the trigger signal.
- Another method to generate the "In Monitor" signal is to click **Reset** and then click **Break**. Going from the reset state of the processor to the "In Monitor" state will generate the signal.
- In addition, an "In Monitor" signal is generated any time a debugger or other user interface reads a register, reads memory, sets breakpoints or steps. Care must be taken to not falsely trigger the logic analyzers listening to the "In Monitor" signal.

Group Run

The intermodule bus signals can still be active even without a Group Run.

The following setups can operate independently of Group Run:

- Port In connected to an emulation module,
- Emulation modules connected in series
- Emulation module connected to Port Out

Here are some examples:

- If "Group Run" is armed from "Port In" and an emulation module is connected to Group Run, then any "Port In" signal will cause the emulation module to go into monitor. The Group Run button does not have to be pressed for this to operate.
- If two emulation modules are connected together so that one triggers another, then the first one going into monitor will cause the second one to go into monitor.
- If an emulation module is connected to Port Out, then the state of the emulation module will be sent out the Port Out without regard to "Group Run".

The current emulation module state (Running or In Monitor) should be monitored closely when they are part of a Group Run measurement so that valid measurements are obtained.

Group Run into an emulation module does not mean that the Group Run will Run the emulation module.

The emulation module Run, Break, Step, and Reset are independent of the Group Run of the Analyzers.

For example, suppose you have the following IMB measurement set up:



Clicking the **Group Run** button (at the very top of the Intermodule window or a logic analyzer window) will start the analyzer running. The analyzer will then wait for an arm signal. Now when the emulation module transitions into "Monitor" from "Running" (or from "Reset"), it will send the arm signal to the analyzer. If the emulation module is "In Monitor" when you click **Group Run**, you will then have to go to the emulation module or your debugger interface and manually start it running.

Debuggers can cause triggers

Emulation module user interfaces may introduce additional states into your analysis measurement and in some cases falsely trigger your analysis measurement.

When a debugger causes your target to break into monitor it will typically read memory around the program stack and around the current program counter. This will generate additional states which appear in the listing.

You can often distinguish these additional states because the time tags will be in the μs and ms range. You can use the time tag information

to determine when the processor went into monitor. Typically the time between states will be in the nanoseconds while the processor is running and will be in the μ s and ms range when the debugger has halted the processor and is reading memory.

Not also that some debugger commands may cause the processor to break temporarily to read registers and memory. These states that the debugger introduces will also show up in you trace listing.

If you define a trigger on some state and the debugger happens to read the same state, then you may falsely trigger your analyzer measurement. In summary, when you are making an analysis measurement be aware that the debugger could be impacting your measurement.

To trigger the analyzer when the processor halts

Remember: if you are only using a state analyzer to capture the processor bus then it will be much simpler to use "Tracing until processor halts" as described on page 98.

- 1** Set the logic analyzer to trigger on **anystate**.
- 2** Set the trigger point to **center** or **end**.
- 3** In the Intermodule window, click on logic analyzer you want to trigger and select the emulation module.

The logic analyzer is now set to trigger on a processor halt.

- 4** Click **Group Run** to start the analyzer(s).
- 5** Click **Run** in the Emulation Control Interface or use your debugger to start the target processor running.

Clicking **Group Run** will *not* start the emulation module. The emulation module run, break, step, reset are independent of the Group Run of the analyzers.

- 6** Wait for the Run Control window in the Emulation Control Interface or the status display in your debugger to show that the processor has stopped.

The logic analyzer will store states up until the processor stops, but may continue running.

You may or may not see a "slow clock" error message. In fact, if you are using a state analyzer on the processor bus the status may never change upon receiving the emulation module trigger (analysis arm). This occurs because the qualified processor clock needed to switch the state analyzer to the next state is stopped. For example, the state analyzer before the arm event may have a status of "Occurrences Remaining in Level 1: 1" and after the arm event it may have the same status of "Occurrences Remaining in Level 1: 1"

- 7** If necessary, in the logic analyzer window, click **Stop** to complete the measurement.

If you are using a timing analyzer or oscilloscope the measurement should complete automatically when the processor halts. If you are using a state logic analyzer, click **Stop** if needed to complete the measurement.

To trigger the analyzer when the processor reaches a breakpoint

This measurement is exactly like the one on the previous page, but with the one additional complexity of setting breakpoints. Be aware that setting breakpoints may cause a false trigger and that the breakpoints set may not be valid after a reset.

Remember: if you are only using a state analyzer to capture the processor bus then it will be much simpler to use "Tracing until processor halts" as described on page 98.

- 1 Set the logic analyzer to trigger on *anystate*.**
- 2 Set the trigger point to *center* or *end*.**
- 3 In the Intermodule window, click on logic analyzer you want to trigger and select the emulation module.**

The logic analyzer is now set to trigger on a processor halt.

- 4 Set the breakpoint.**

If you are going to run the emulation module from Reset you must do a **Reset** followed by **Break** to properly set the breakpoints. The Reset will clear all on-chip hardware breakpoint registers. The Break command will then reinitialize the breakpoint registers. If you are using software breakpoints which insert an illegal instruction into your program at the breakpoint location you will not need to do the Reset, Break sequence. Instead you must take care to properly insert your software breakpoint in your RAM program location.

- 5 Click *Group Run* to start the analyzer(s).**
- 6 Click *Run* in the Emulation Control Interface or use your debugger to start the target processor running.**

Clicking **Group Run** will *not* start the emulation module. The emulation module run, break, step, reset are independent of the Group Run of the analyzers.

- 7 Wait for the Run Control window in the Emulation Control Interface or the status display in your debugger to show that the processor has stopped.**

The logic analyzer will store states up until the processor stops, but may continue running.

You may or may not see a "slow clock" error message. In fact, if you are using a state analyzer on the processor bus the status may never change upon receiving the emulation module trigger (analysis arm). This occurs because the qualified processor clock needed to switch the state analyzer to the next state is stopped. For example, the state analyzer before the arm event may have a status of "Occurrences Remaining in Level 1: 1" and after the arm event it may have the same status of "Occurrences Remaining in Level 1: 1"

- 8** If necessary, in the logic analyzer window, click **Stop** to complete the measurement.

If you are using a timing analyzer or oscilloscope the measurement should complete automatically when the processor halts. If you are using a state logic analyzer, click **Stop** if needed to complete the measurement.

Updating Firmware

Updating Firmware

Firmware gives your emulator a “personality” for a particular processor or processor family.

After you have connected the emulator to your target system, you may need to update the firmware to give it the right personality for your processor.

You must update the firmware if:

- You have an emulation module which was not shipped already installed in the logic analysis system.
- You need to change the personality of the emulator for a new processor.
- You have an updated version of the firmware from Agilent Technologies.

The procedure for updating firmware for an emulation probe is different from the procedure for updating firmware for an emulation module.

Emulation Probe Firmware

To display current firmware version information

- Use telnet or a terminal emulator to access the built-in "terminal interface" and use the ver command to view the version information for firmware currently in the emulation probe.

To update firmware for an emulation probe

To update the firmware, you must have access to the World Wide Web and a PC or a workstation connected to your emulation probe.

1 Download the new firmware from the following World Wide Web site:

<http://www.hp.com/go/emulator>

The firmware will be in the "Technical Support Information" section of this web site.

2 Follow the instructions on the web site for installing the firmware.

If Agilent Technologies sends you firmware on a floppy disk, install the firmware from the floppy disk. The README file on the floppy disk contains instructions for installing the firmware using a PC or workstation.

If there is a power failure during a firmware update

If there is a power glitch during a firmware update, some bits may be lost during the download process, possibly resulting in an emulation probe that will not boot up.

- Set switch S4 to OPEN, then cycle power. This tells the emulation probe to ignore everything in the Flash EPROM except the boot code.
- Repeat the firmware update process.
- Set switch S4 to CLOSED, then cycle power. This restores the emulation probe to its normal mode.

Emulation Module Firmware

Always update firmware by installing a processor support package. This will ensure that the version of the Emulation Control Interface software is compatible the version of the emulator firmware.

To display current firmware version information

- 1 In the Update Firmware window, click **Display Current Version**.
There are usually two firmware version numbers: one for “Generics” and one for the personality of your processor.

To update firmware for an emulation module using the Emulation Control Interface

- 1 End any run control sessions which may be running.
- 2 In the Workspace window, remove any Emulator icons from the workspace.
- 3 Install the processor support package from the CD-ROM, if necessary.
- 4 In the system window, click the emulation module and select **Update Firmware....**

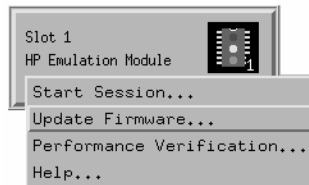

- 5** In the Update Firmware window, select the firmware to load into the emulation module.
- 6** Click **Update Firmware**.

In about 20 seconds, the firmware will be installed and the screen will update to show the current firmware version.

See also

“Installing Software” beginning on page 38 for instructions on how to install the processor support package from the CD-ROM.

To update firmware for an emulation module using the Setup Assistant

The Setup Assistant is an online tool for connecting and configuring your logic analysis system for microprocessor and bus analysis. The Setup Assistant is available on the Agilent Technologies 16600A and 16700A-series logic analysis systems.

This menu-driven tool will guide you through the connection procedures for connecting the logic analyzer to an analysis probe, an emulation module, or other supported equipment. It will also guide you through connecting an analysis probe to the target system.

Do not use the Setup Assistant to connect an emulation probe if you already have an emulation module installed.

- 1** Install the processor support package from the CD-ROM.
- 2** Start the Setup Assistant by clicking its icon in the system window.
- 3** Follow the instructions displayed by the Setup Assistant.

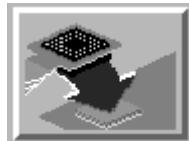
**See also**

Page 51 for instructions on how to install a the processor support package from the CD-ROM.

Specifications and Characteristics

The following operating characteristics are not specifications, but are typical operating characteristics for the Agilent Technologies 16610A emulation module, emulation probe, and MPC821/860 target interface module.

Processor Compatibility

The Agilent Technologies E3497A MPC800 embedded PowerPC emulator supports the MPC860, MPC 821, MPC801, and MPC850 microprocessors.

Emulation Probe Electrical Characteristics

BNC, labeled TRIGGER OUT

Output Drive Logic high level with 50-ohm load ≥ 2.0 V. Logic low level with 50-ohm load ≤ 0.4 V. Output function is selectable by the Agilent Technologies 16505A Prototype Analyzer. Refer to Online Help for more information.

BNC, labeled BREAK IN

Input Edge-triggered TTL level input (active high), 20 pf, with 2K ohms to ground in parallel. Maximum input: 5 V above V_{CC} ; 5 V below ground. Input function is selectable by the Agilent Technologies 16505A Prototype Analyzer. Refer to Online Help for more information. The BNC introduces approximately 2.5 ms skid after break-in at 25 MHz.

Communications

Serial Port 9-pin female type “D” subminiature connector. RS-232 DCE to 115.2 kbaud.

10BASE-T LAN Port RJ-45 connector. IEEE 802.3 10BASE-T (StarLAN).

10BASE 2 LAN Port 50-ohm BNC connector. IEEE 802.3 10BASE2 (ThinLAN). When using this connector, the emulation probe provides the functional equivalent of a Medium Attachment Unit (MAU) for ThinLAN.

Accessory Power Out

12 V, 3.0A, center negative

Power Supply

Input 100-240 V, 1.0 A, 50/60 Hz, IEC 320 connector.

Output 12 V, 3.3 A

Emulation Probe and Emulation Module Electrical Characteristics

Maximum Ratings

Characteristics for the MPC800 Embedded PowerPC emulator	Notes	Symbol	Min	Max	Unit
Input voltage range		V_{in}	-0.5	5.5	V
Input voltage range (V_{tt})			1.3	1.7	V
Input High Voltage		V_{ih}	$\frac{2}{3}V_{tt} + 0.2$		V
Input Low Voltage		V_{il}		$\frac{2}{3}V_{tt} - 0.2$	V
Input High Current		I_{ih}		-15	μA
Input Low Current		I_{il}		100	μA
Output High Voltage		V_{oh}	2.4	3.3	V
Output Low Voltage		V_{ol}		0.5	V
Output High Current		I_{oh}	8		mA
Output Low Current		I_{ol}	-16		mA

Emulation Probe Environmental Characteristics

Temperature

Operating, 0 to +40 °C (+32 to +104 °F); nonoperating, -40 to +60 °C (-40 to +140 °F).

Altitude

Operating/nonoperating 4600 m (15 000 ft).

Relative Humidity

15% to 95%.

For indoor use only.

Emulation Module Environmental Characteristics

The Agilent Technologies 16610A emulation module meets the environmental characteristics of the logic analysis system in which it is installed.

For indoor use only.

Troubleshooting the Emulator

Troubleshooting the Emulator

If you have problems with the emulator, your first task is to determine the source of the problem. Problems may originate in any of the following places:

- The connection between the emulator and your debugger
- The emulation module or emulation probe itself
- The connection between the emulator and the target interface module
- The connection between the target interface module and the target system
- The target system

You can use several means to determine the source of the problem:

- The troubleshooting guide on the next page
- The status lights on the emulation probe or emulation module
- The emulator "performance verification" tests
- The emulator's built-in "terminal interface" commands

Troubleshooting Guide

Common problems and what to do about them

Symptom	What to do	See also
Commands from the Emulation Control Interface have no effect	Check that you are using the correct firmware.	
Commands from debugger have no effect	Use the Emulation Control Interface to try a few built-in commands. If this works, your debugger may not be configured properly. If this does not work, continue with the steps for the next symptom....	page 123
Emulator built-in commands do not work	<p>1 Check that the emulator has been properly configured for your target system.</p> <p>2 Run the emulator performance verification tests.</p> <p>3 If the performance verification tests pass, then there is an electrical problem with the connection to the target processor OR the target system may not have been designed according to "Designing a Target System."</p>	<p>page 64</p> <p>page 143</p> <p>page 58, page 131</p>
"Slow or missing clock" message after a logic analyzer run	Check that the target system is running user code or is in reset. (This message can appear if the processor is in background mode.)	
"Slow clock" message in the Emulation Control Interface or "c>" prompt in the built-in terminal interface	Check that the clock rate is properly configured.	page 69
Some commands fail	Check the "restrict to real-time runs" configuration	page 70
Host computer reports LAN connection problems	Follow the checklist in the "If you have LAN problems" section.	page 126
Commands from the Run Control tool or debugger have no effect	Verify LAN communication.	page 37

Status Lights

Emulation Module Status Lights

The emulation module uses status lights to communicate various modes and error conditions.

The following table gives more information about the meaning of the power and target status lights.

○ = LED is off

● = LED is on

* = Not applicable (LED is off or on)

Power/Target Status Lights

Pwr/Target LEDs	Meaning
<input type="radio"/> Reset <input type="radio"/> Break <input type="radio"/> Run	No target system power, or emulation module is not connected to the target system
<input checked="" type="radio"/> Reset <input type="radio"/> Break <input type="radio"/> Run	Target system is in a reset state
<input type="radio"/> Reset <input checked="" type="radio"/> Break <input type="radio"/> Run	The target processor is executing in Debug Mode
<input type="radio"/> Reset <input type="radio"/> Break <input checked="" type="radio"/> Run	The target processor is executing user code
<input type="radio"/> Reset <input checked="" type="radio"/> Break <input checked="" type="radio"/> Run	Only boot firmware is good (other firmware has been corrupted)

Emulation Probe Status lights

The following illustration shows the status lights on both sides of the emulation probe and what they mean:

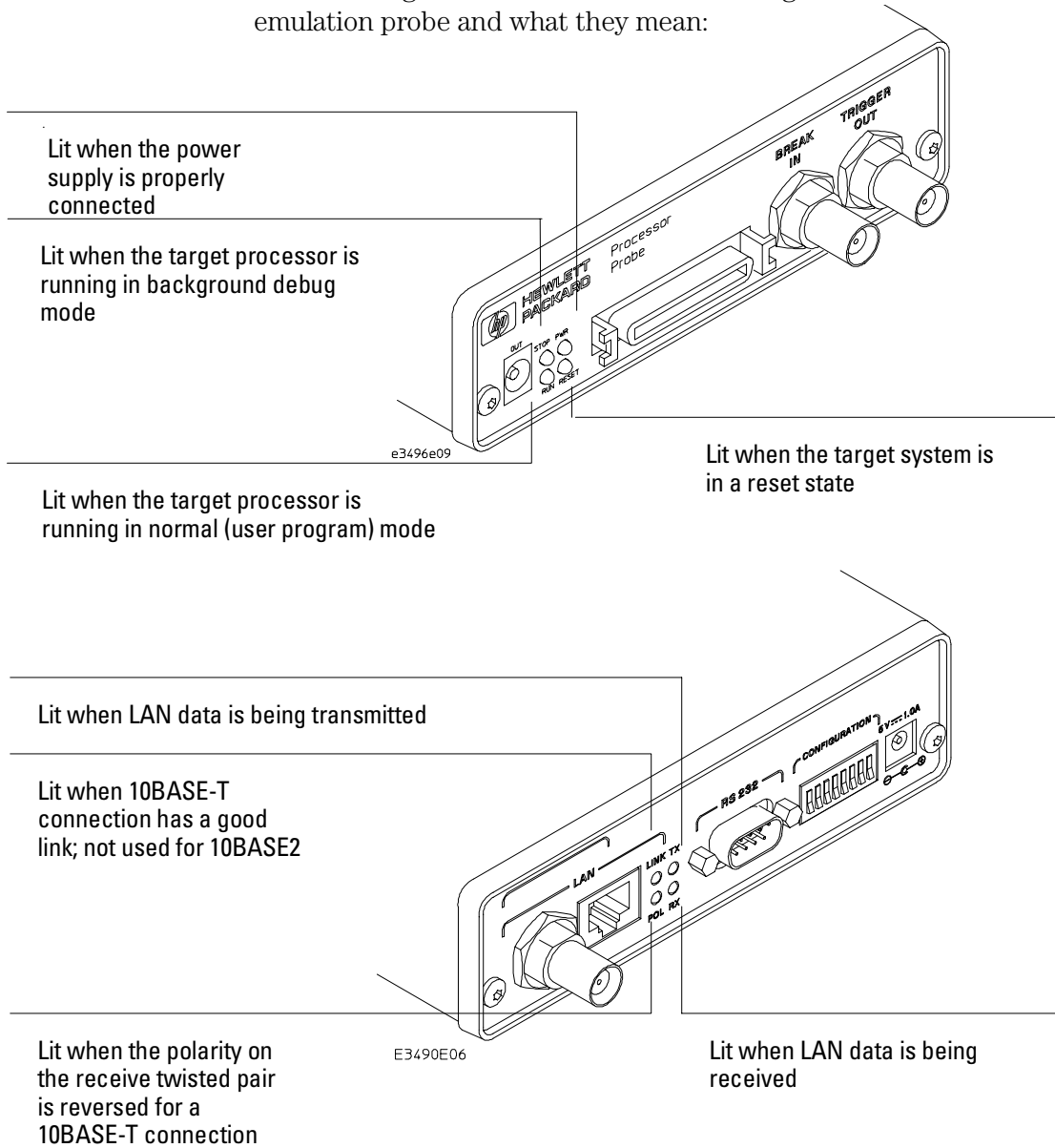

The emulation probe communicates various modes and error conditions via the status lights. The meanings of the status lights are shown on the previous page.

The following table gives more information about the meaning of the power and target status lights.

- = LED is off
- = LED is on
- * = Not applicable (LED is off or on)

Power/Target Status Lights

Pwr/Target LEDs	Meaning
○○	emulation probe is not connected to power supply
○○	
○●	No target system power, or emulation probe is not connected to the target system
○○	
○●	Target system is in a reset state
○●	
●●	Only boot firmware is good (other firmware has been corrupted)
●○	
●●	The target processor is executing in Debug Mode
○○	
○●	The target processor is executing user code
●○	

Emulator Built-in Commands

The emulator has some built-in "terminal interface" commands which you can use for troubleshooting. You can access the terminal interface using:

- A telnet (LAN) connection
- The Command Line window in the Emulation Control Interface
- A "debugger command" window in your debugger
- A serial connection (see page 38)

To telnet to the emulator

You can establish a telnet connection to the emulator if:

- A host computer and the logic analysis system are both connected to a local-area network (LAN), and
- The host computer has the telnet program (often part of the operating system or an internet software package).

To establish a telnet connection:

1 Find out the port number of the emulator.

The default port number of an emulation probe or the first emulation module in an Agilent Technologies 16600A/700A series logic analysis system is 6472. The default port of a second module in an Agilent Technologies 16600A-series system is 6476. The default port numbers of a third and fourth module in an expansion frame are 6480 and 6484. These port numbers can be changed, but that is rarely necessary.

2 Find out the LAN address or LAN name of the logic analysis system.

3 Start the telnet program.

If the LAN name of the logic analysis system is "test2" and you have only one emulation module installed, the command might look like this:

```
telnet test2 6472
```

4 If you do not see a prompt, press the <Return> key a few times.

To exit from this telnet session, type <CTRL>D at the prompt.

To use the built-in commands

Here are a few commonly used built-in commands:

Useful built-in commands

b	Break—go into the background monitor state
cf	Configuration—read or write configuration options
help	Help—display online help for built-in commands
init	Initialize—init -c re-initializes everything in the emulator except for the LAN software; init -p is the equivalent of cycling power (it will break LAN connections)
lan	configure LAN address
m	Memory—read or write memory
reg	Register—read or write a register
r	Run—start running user code
rep	Repeat—repeat a command or group of commands
rst	Reset—reset the target processor (the emulator will wait for you to press the target's RESET button)
s	Step—do a low-level single step
ver	Version—display the product number and firmware version of the emulator

The prompt indicates the status of the emulator:

Emulator prompts

U	Running user program
M	Running in background monitor
p	No target power
R	Emulation reset
r	Target reset
?	Unknown state

Examples

To set register R0, then view R0 to verify that it was set, enter:

```
R>rst -m
M>reg r0=ffff
M>reg r0
   reg R0=0000ffff
```

To break execution then step a single instruction, enter:

```
M>b
M>s
   PC=xxxxxxxx
M>
```

To determine what firmware version is installed in the emulator, enter:

```
M>ver
```

See Also

Use the `help` command for more information on these and other commands. Note that some of commands listed in the help screens are generic commands for Agilent Technologies emulators and may not be available for your product.

If you are writing your own debugger, contact Agilent Technologies for more information.

Problems with the LAN Interface (Emulation Probe Only)

If you cannot verify LAN communication

If you cannot verify connection using the procedure in "To verify LAN communication", or if the commands are not accepted by the emulation probe:

- Make sure that you have connected the emulation probe to the proper power source and that the power light is lit.
- Make sure that you wait for the power-on self test to complete before connecting.
- Make sure that the LAN cable is connected. Watch the LAN LED's to see whether the emulation probe is seeing LAN activity. Refer to your LAN documentation for testing connectivity.
- Make sure that only one of the LAN ports is connected.
- Make sure the emulation probe communication configuration switches are set correctly. Unplug the emulation probe power cord, then plug it in again to make sure the switch settings are read correctly by the emulation probe.
- Check that the Run Control Tool or debugger was configured with the correct LAN address. If the emulation probe is on a different subnet than the host computer, check that the gateway address is correct.
- Make sure that the emulation probe's IP address is set up correctly. Use the RS-232 port to verify this that the IP address is set up correctly. When you are connected to the RS-232 port, run performance verification on the emulation probe's LAN interface with the "pv" command.

- It's also possible for there to be a problem with the emulation probe firmware while the LAN interface is still up and running. In this case, you must reboot the emulation probe by disconnecting power to the emulation probe and reconnecting it again.
- Use a serial connection to run the LAN performance verification tests (see page 143).

If you have LAN connection problems

- If the emulation probe does not accept commands from the logic analysis system:
 1. Check that switch S1 is "0" (attached to LAN, not RS-232).
 2. Check that switch S5 is in the correct position for your LAN interface (either 10BASE2 or 10BASE-T).(Remember: if you change any switch settings, the changes do not take effect until you cycle power.)
- If the emulation probe still does not respond, you need to verify the IP address and gateway mask of the emulation probe. To do this, connect the emulation probe to a terminal or terminal emulator (see page 38), change the switch settings so it is connected to RS-232, and enter the "lan" command. The output looks something like this:

```
lan -i 15.5.24.116
lan -g 15.5.23.1
lan -p 6470
Ethernet Address : 08000909BAC1
```

"lan -i" shows the internet address is 15.5.24.116 in this case. If the Internet address (IP) is not what you expect, you can change it with the 'lan -i <new IP>' command.

"lan -g" shows the gateway address. Make sure it is the address of your gateway if you are connecting from another subnet, or 0.0.0.0 if you are connecting from the local subnet.

"lan -p" shows the port is 6470. If the port is not 6470, you must change it with the "lan -p 6470" command (unless you have deliberately set the port number to a different value because of a conflict).

If the "POL" LED is lit

The "POL" LED indicates that the polarity is reversed on the receive pair if you are using a 10BASE-T connection. The emulation probe should still work properly in this situation, but other LAN devices may not work.

If it takes a long time to connect to the network

- Check the subnet masks on the other LAN devices connected to your network. All of the devices should be configured to use the same subnet mask.

Subnet mask error messages do not indicate a major problem. You can continue using the emulation probe.

The emulation probe automatically sets its subnet mask based on the first subnet mask it detects on the network. If it then detects other subnet masks, it will generate error messages.

If there are many subnet masks in use on the local subnet, the emulation probe may take a very long time to connect to the network after it is turned on.

To "clean up" the network, connect a terminal to the emulation probe. You can then see error messages which will help you identify which devices on the network are using the wrong subnet masks.

Problems with the Serial Interface (Emulation Probe Only)

If you cannot verify RS-232 communication

If the emulation probe prompt does not appear in the terminal emulator window:

- Make sure that you have connected the emulation probe to the proper power source and that the power light is lit.
- Make sure that you have properly configured the data communications switches on the emulation probe and the data communications parameters on the host computer. You should also verify that you are using the correct cable.

The most common type of data communications configuration problem involves the configuration of the emulation probe as a DTE device instead of as a DCE device. If you are using the wrong type of cable, no prompt will be displayed.

A cable with one-to-one connections will work with a PC or an HP 9000 Series 700 workstation.

If you have RS-232 connection problems with the MS Windows Terminal program

- Remember that Windows 3.1 only allows two active RS-232 connections at a time. To be warned when you violate this restriction, choose Always Warn in the Device Contention group box under 386 Enhanced in the Control Panel.
- Use the "Terminal" program (usually found in the Accessories windows program group) and set up the "Communications..." settings as follows:

Baud Rate: 9600 (or whatever you have chosen for the emulator)

```
Data Bits: 8  
Parity: None  
Flow Control: hardware  
Stop Bits: 1
```

When you are connected, hit the Enter key. You should get a prompt back. If nothing echos back, check the switch settings on the emulation probe.

- If the switches are in the correct position and you still do not get a prompt when you hit return, try turning OFF the power to the emulation probe and turning it ON again.
- If you still don't get a prompt, make sure the RS-232 cable is connected to the correct port on your PC, and that the cable is appropriate for connecting the PC to a DCE device.

With certain RS-232 cards, connecting to an RS-232 port where the emulation probe is turned OFF (or is not connected) will hang the PC. The only way to get control back is to reboot the PC. Therefore, we recommend that you always turn ON the emulation probe before attempting to connect via RS-232.

Problems with the Target System

This section describes how to determine whether your target system is causing problems with the operation of the emulator.

What to check first

- 1 Try some basic built-in commands using the Command Line window or a telnet connection:

```
U>rst  
R>
```

This should reset the target and display a "R>" prompt.

```
R>b  
M>
```

This should stop the target and display an "M>" prompt.

```
M>reg r1  
reg r1=00000000  
M>
```

This should read the value of the r1 register (the value will probably be different on your target system).

```
M>m 0..  
00000000 7c3043a6 7c2802a6 7c3143a6 4bf04111  
00000010 00000000 00000000 00000000 00000000  
00000020 00000000 00000000 00000000 00000000  
00000030 00000000 00000000 00000000 00000000  
00000040 00000000 00000000 00000000 00000000  
00000050 00000000 00000000 00000000 00000000  
00000060 00000000 00000000 00000000 00000000  
00000070 00000000 00000000 00000000 00000000  
M>
```

This should display memory values starting at address 0.

```
M>s
```

This should execute one instruction at the current program counter.

If any of these commands don't work, there may be a problem with the design of your target system, a problem with the revision of the emulation you are using, or a problem with the configuration of the emulator. The following steps will help you identify the problem.

- 2 Check that the emulator firmware matches your processor. To do this, enter:**

M>ver

See Also

Page 123 for information on entering built-in commands.

To interpret the initial prompt

The initial prompt can be used to diagnose several common problems. To get the most information from the prompt, follow this procedure:

- 1 Connect the emulator to your target system.
- 2 Set the default configuration settings. Enter:

```
M>init -c
```

You can enter this command at any prompt. The emulator will respond with the same information as printed by the "ver" command.

If the response is "!ERROR 905! Driver firmware is incompatible with ID of attached device"

Make sure the target interface module is connected to the cable of the emulator, then try the "init -c" command again.

If the initial prompt is "p>"

Check pin 9 on header, 3.3V (V_{OD}).

If the initial prompt is "M>"

The processor entered debug mode without the help of the emulator. Is another debugger connected?

If the initial prompt is "U>"

The emulator is scanning the instruction register correctly. Now you can do some more tests:

4 Enter the reset command:

```
U>rst  
R>
```

The "R>" prompt is a good response that indicates SRESET and HRESET are working.

If interrupts are non-recoverable

- Check that interrupt service routines (ISRs) in the target code meet the requirements listed in the PowerPC documentation.

For proper debugging in ISR's, the PowerPC documentation specifies that the exception handlers must do the following:

- As an epilogue to the ISR:
 - Save the SRR0, SRR1, DAR, DSISR registers
 - Set the RI bit in the MSR (Machine State Register.Recoverable Interrupt Bit)
- As a prologue to the ISR:
 - Restore the SRR0, SRR1, DAR, DSISR registers
 - Issue an RFI (Return from Interrupt) instruction

Upon entering the ISR, the processor clears the MSR.RI bit, and copies the IP (Instruction Pointer)->SRR0 and the MSR->SRR1. The SRR0 and SRR1 are the save and restore registers. These contain the necessary information needed to return to the state prior to the interrupt.

The RI bit will prevent the processor from breaking into debug mode with a maskable debug port breakpoint. A non-maskable breakpoint is required to break the processor when the RI bit is cleared, resulting in a possible non-recoverable state.

Software breakpoints place a 'Trap' instruction into the breakpoint address. If the trap instruction is executed within an ISR, a break to background mode will occur. This causes the SRR0 and SRR1 registers to be written over, causing a non-recoverable state. If the exception handler saves these registers, and sets the MSR.RI bit, the software breakpoint will always be recoverable.

If hardware breakpoints have no effect

Hardware breakpoints by default will not break the processor if they are set within an exception handler which has not saved the SRR's and set the MSR.RI bit. However, these can quite easily be reprogrammed to assert a non-maskable break. Note that the breakpoint will halt the processor, but will cause a non-recoverable state.

To reprogram the hardware breakpoint to assert a non-maskable break:

```
M>bc -e hwbp
M>reg lctrl2
reg lctrl2=02018000
M>reg lctrl2=02018800 # OR in 0x00000800 with previous value
```

Hardware breakpoints will now cause a non-maskable break, which will halt the processor regardless of the status of the MSR.RI bit. Again, note that in this case the break will be non-recoverable if the exception handler has not saved the SRR's.

If the target resets itself

The most common plug-in issue is the target is resetting itself. If the PC is set to some initial location, and then a short time later, the PC=100 or PC=fff00100, the target is resetting itself. In most cases, the chip is causing the reset, not the target hardware.

There are a number of possible causes of the reset. To determine the cause of reset, read the RSR (Reset Status Register):

```
M>m -a2 -d2 288@reg # telnet command which reads the RSR
```

The bits in this register show the cause of the reset:

RSR Bit Encoding

Bit	Cause of reset	Explanation
MSB 0	External Hard Reset	The emulator actually uses an external reset when resetting the target.
	External Soft Reset	
2	Loss of Lock	Caused when the PLL loses the phase lock on the external clock source.
3	SW Watchdog	Make sure the SYPCR register disables the watchdog timer. R>reg cf_sypcr=fffff88 or M>m -a4 -d4 4@reg=fffff88
4	Checkstop	Occurs when the processor enters a checkstop state.
5	Debug Port Hard Reset	
6	Debug Port Soft Reset	
7	JTAG Reset	

To clear the RSR, execute the following:

```
M>m -a2 -d2 288@reg=fff
```

If running from reset causes problems

Running from reset may cause some problems once background is entered. To insure proper operation, the DER register must have bits 31,30,29,28 set (0x0000000f), and the SYPCR register must have the 'Disable watchdog freeze' bit set (0x00000080).

If you see the "!ASYNC_STAT 173!" error message

If after a break, the following error arises:

```
!ASYNC_STAT 173! MSR.RI bit not set - Break may not be  
recoverable
```

This indicates that the MSR.RI bit is not set, implying that a non-maskable break was needed, and the interrupt may not be recoverable. If this occurs while breaking out of regular code, then the MSR.RI bit was not set in the boot code. This can be fixed by 'ORing' in 0x00000002 into the SRR1 register and resuming the run.

If there are problems with the debug port signals

- Check for pull down resistors on DSDI and DSCK.

Some target systems may have 220 Ohm pull downs on these two signals. These signals are series terminated by the analysis probe or TIM with a 46 Ohm resistor. A 220 Ohm pull-down would present a 20% drop in signal level when driven high, which could easily cause some malfunctions. There should be a very weak pull down on the target, if any at all. If you want to pull-down DSCK, use a value of 2.2K or greater.

To test the target system

The following program can be placed into memory.

```
start:  addi  r1,1      - 0x38210001
        nop          - 0x60000000
        nop          - 0x60000000
        bra   start   - 0x4bfffff4
```

The opcode 0x4bfffff4 is a branch to a relative offset, so this program can be placed at any start address.

```
M>reg r1=0
M>m -a2 -d2 10000=3821,1,6000,0,6000,0,4bff,fff4
M>r 10000
U>reg r1
reg r1=00034567    # or some number
U>reg r1
reg r1=00102333    # or some number
U>
```

This program will loop forever, incrementing r1. This is a good test program to load once a memory system is up to make sure the microprocessor can run code out of memory.

Problems with the LAN Interface

If LAN communication does not work

If you cannot verify connection using the procedure in "To verify LAN communication", or if the commands are not accepted by the emulator:

- Make sure that you wait for the power-on self test to complete before connecting.
- Make sure that the LAN cable is connected. Watch the LAN LED's on the back of the logic analysis system to see whether the system is seeing LAN activity. Refer to your LAN documentation for testing connectivity.
- Check that the host computer or debugger was configured with the correct LAN address. If the logic analysis system is on a different subnet than the host computer, check that the gateway address is correct.
- Make sure that the logic analysis system's IP address is set up correctly.

If it takes a long time to connect to the network

- Check the subnet masks on the other LAN devices connected to your network. All of the devices should be configured to use the same subnet mask.

Subnet mask error messages do not indicate a major problem. You can continue using the emulator.

The subnet masks is set in the logic analysis system's System Admin window. If it then detects other subnet masks, it will generate error messages.

If there are many subnet masks in use on the local subnet, the logic analysis system may take a very long time to connect to the network after it is turned on.

Problems with the Emulation Probe

To run the power up self test

- 1 Unplug the emulation probe, then plug it in.
- 2 Watch the status lights. They should show the following pattern:

○ = LED is off

● = LED is on

* = Not applicable (LED is off or on)

Normal sequence during power up self test

	Pwr/Target LEDs	Meaning
1	○● ○	Initial power up, system reset
2	○● ○	XILINX array initialized successfully
3	○● ●○	XILINX array tested successfully
4	●● ○	BOOT ROM space tested successfully
5	○● ●○	GENERIC ROM space tested successfully
6	●● ○	DRIVER ROM space tested successfully
7	○● ●○	RESERVED ROM space tested successfully
8	●● ○	RAM tested successfully
9	○● ●○	LAN internal feedback tested successfully
10	○● ○	Boundary scan master (BSM) test begun

	Pwr/Target LEDs	Meaning
11	●● ●○	BSM test completed, start system, load drivers, initialize LAN

If the power up self test fails, the RESET LED will flash the number of the test, then stay lit.

If any of the LEDs fail to change, or all of them remain on, there is a system failure.

Following power up, the LEDs will enter one of the following states:

○● ○○	No target system power, or emulation probe is not connected to the target system, or
○● ○●	Target system is in a reset state
●● ●○	Only the boot ROM was used; other firmware in the Flash EPROM has been corrupted

Starting a user interface will change the pattern to the one requested by the interface.

If the power up self tests fail, try the following:

- Check and reset the LAN address as shown in the "Connecting to a Host Computer" chapter. LAN powerup failures will occur if the emulation probe does not have a valid Link Level Address and IP Address.
- Disconnect all external connections, including the LAN, serial (RS-232), and BNC Break and Trigger cables, then cycle power.
- To ensure that the firmware is working as it should, reprogram the firmware, then cycle power.

To execute the built-in performance verification test (emulation probe only)

In addition to the powerup tests, there are several additional performance verification (PV) tests available.

Some of these tests can be performed through the logic analysis system. The LAN tests can only be executed through the RS-232 port.

To perform the PV tests through the logic analysis system

- 1 End any Emulation Control Interface sessions.
- 2 Disconnect the 50-pin cable from the emulation probe, and plug the loopback test board into the emulation probe.

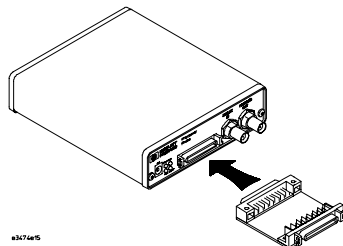

- 3 From the emulation probe icon menu, open the Performance Verification window.
- 4 Enter the LAN address of the emulation probe.
- 5 Select the number of iterations to perform.
- 6 Click **Start PV**.

The results will appear on screen.

Additional PV Tests

The LAN tests can only be executed through the RS-232 port. The remainder of this section assumes that the tests are being run from a terminal emulator connected to the RS-232 port.

For the BREAK IN, TRIGGER OUT BNC FEEDBACK TEST, connect a coaxial cable between BREAK IN and TRIGGER OUT

For the TARGET PROBE FEEDBACK TEST, connect the self-test board (Agilent part number E3496-66502).

- 1 Set all of the switches to OPEN.

This is standard RS-232 at 9600 baud which can be connected directly to a 9 pin RS-232 interface that conforms to the IBM PC-AT 9 pin standard.

- 2 Use a terminal emulator to connect to the emulation probe.
- 3 Enter the **pv** command.

Options available for the "pv" are explained in the help screen displayed by typing "help pv" or "? pv" at the prompt.

Examples:

To execute both tests one time:

```
pv 1
```

To execute test 2 with maximum debug output repeatedly until a ^C is entered:

```
pv -t2 -v9 0
```

To execute tests 3, 4, and 5 only for 2 cycles:

```
pv -t3-5 2
```

On a good system, when the feedback connector is plugged into the target connector, the RESET LED will light and the BKG and USER LEDs will be out.

The results on a good system, with the BNC's connected, and with the self-test board plugged in, are as follows:

```
R>pv 1
```

```
Testing: E3499A Series Emulation System
Test # 1: Powerup PV Results           Passed!
Test # 2: LAN 10Base2 Feedback Test    Passed!
Test # 3: LAN 10BaseT Feedback Test    Passed!
Test # 4: Break In and Trigger Out BNC Feedback Test Passed!
Test # 5: Target Probe Feedback Test   Passed!
Test # 6: Boundary Scan Master Test    Passed!
Test # 7: I2C                          Passed!
PASSED Number of tests: 1              Number of failures: 0
```

Copyright (c) Agilent Technologies 1987

All Rights Reserved. Reproduction, adaptation, or translation without prior written permission is prohibited, except as allowed under copyright laws.

```
E3499A Series Emulation System
Version: A.05.05 18Nov96 07:47 Proto
```

Location: Generics

E3497A MPC800 Embedded PowerPC Emulator
Version: A.01.06 26Nov96 13:03 Proto

There are some things you can do if a failure is found on one of these tests. Details of Failure can be obtained through using a verbose level of 2 or more. If the particular failure you see is not listed below, contact Agilent Technologies for assistance.

TEST 2: LAN 10BASE2 Feedback Test failed

For LAN 10BASE2 test, the following is an example of a failure which is *not* caused by a broken emulation probe.

```
R>pv -t2 -v2 1
```

```
Testing: E3499A Series Emulation System
Test # 2: LAN 10Base2 Feedback Test                failed!
  FAILED - no lan connection (LAN probably not terminated)
FAILED Number of tests: 1          Number of failures: 1
```

Check to see that the port under test has a good cable connected to it and that the cable is properly terminated with a 50 ohm terminator on each end of the overall cable.

```
R>pv -t2 -v2 1
```

```
Testing: E3499A Series Emulation System
Test # 2: LAN 10Base2 Feedback Test                failed!
  FAILED due to excessive collisions
FAILED Number of tests: 1          Number of failures: 1
```

The most common cause of this problem is poor termination of the cable or failure to remove the port under test from the LAN before performing the test. Check to see that the terminators are good (50 Ohms) and that you are isolated from any traffic on a system LAN.

```
R>pv -t2 -v2 1
```

```
Testing: E3499A Series Emulation System
Test # 2: LAN 10Base2 Feedback Test                failed!
  FAILED - invalid Ethernet address in EEPROM
FAILED Number of tests: 1          Number of failures: 1
```

First check to see that a correct LLA and IP address have been set in the virtual EEPROM through the "lan" command. If the "lan" command shows bad

information for the LLA and IP, then try to set them to correct values. If you are unable to set them to correct values, there is a failure in the FLASH ROM which requires service from Agilent Technologies.

Test 3: 10BaseT Feedback Test failed

```
R>pv -t3 -v2 1
```

```
Testing: E3499A Series Emulation System
Test # 3: LAN 10BaseT Feedback Test      passed!
PASSED Number of tests: 1                Number of failures: 0
```

In addition to the internal checks performed in Test 2, this test also checks for shorts on the cable connected to the network. If this test fails, disconnect the cable and run the test again. If it then passes, the cable is faulty. If it still fails, it requires service from Agilent Technologies.

If the emulation probe passes this "pv" test, additional testing can be performed through exercising the connection to the network. To run this test, set configuration switch 1 and switch 5 to OPEN, all other configuration switches CLOSED (this enables LAN using 10BaseT). Cycle power and wait for 15 to 30 seconds. Then "ping" the emulation probe from your host computer or PC. See the LAN documentation for your host computer for the location and action of the "ping" utility. If the emulation probe fails to respond to the "ping" request, verify that the lan parameters (IP address and gateway address) are set correctly and that your host computer recognizes the IP address of the emulation probe. If all else is good, then failure to respond to ping indicates a faulty emulation probe.

E3499A TEST 4: Break In and Trigger Out BNC Feedback Test

```
R>pv -t4 -v2 1
```

```
Testing: E3499A Series Emulation System
Test # 4: Break In and Trigger Out BNC Feedback Test      failed!
Break In not receiving Break Out HIGH
FAILED Number of tests: 1                Number of failures: 1
```

Before returning to Agilent Technologies, check to ensure that you have connected a good Coaxial cable between the two BNCs. If the cable is good, the emulation probe is bad.

TEST 5: Target Probe Feedback Test

A verbose output on this test can be extensive. For example, the following is the output of this test if you forget to plug in the self-test board.

```
p>pv -t5 -v2 1
```

```
Testing: E3499A Series Emulation System
Test # 5: Target Probe Feedback Test                                     failed!
  Bad 20 Pin Status Read when unconnected = 0x7fb7
      Expected Value = 0xffb7
  Bad 20 Pin Status Read when connected= 7fb7
      Expected Value = 0x7fb7
  Output 19 Low not received on Input 11
  Output 11 Low not received on Input 19
  Output 13 Low not received on Input 1
  Output 12 High not received on Input 6
  Output 12 and Input 6 not pulled high on release
  Output 8 Low not received on Input 10
  Output 7 Low not received on Input 20
  Output 4 Low not received on Input 14
  Output 2 Low not received on Input 18
FAILED Number of tests: 1          Number of failures: 1
```

If the you get a verbose output like this, check to make sure that the self test board was connected properly.

Problems with the Emulation Module

Occasionally you may suspect a hardware problem with the emulation module or target interface module. The procedures in this section describe how to test the hardware, and if a problem is found, how to repair or replace the broken component.

To run the built-in performance verification test using the logic analysis system (emulation module only)

- 1 End any Emulation Control Interface or debugger sessions.
- 2 Disconnect the 50-pin cable from the emulation module, and plug the loopback test board (Agilent part number E3496-66502) into the emulation module.

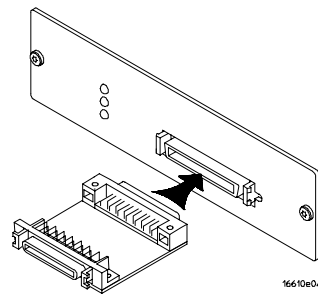

- 3 In the system window, click the emulation module and select **Performance Verification**.
- 4 Click **Start PV**.
The results will appear onscreen.

To run complete performance verification tests using a telnet connection (emulation module only)

- 1 Disconnect the 50-pin cable from the emulation module, and plug the loopback test board (Agilent part number E3496-66502) directly into the emulation module. Do not plug anything into the other end of the loopback test board.

On a good system, the RESET LED will light and the BKG and USER LEDs will be out.

- 2 telnet to the emulation module.
- 3 Enter the **pv 1** command.

See Also

Options available for the "pv" command are explained in the help screen displayed by typing "help pv" or "? pv" at the prompt. Note, however, that some of the options listed may not apply to your emulator.

Examples:

If you are using a UNIX system, to telnet to a logic analysis system named "mylogic", enter:

```
telnet mylogic 6472
```

Here are some examples of ways to use the **pv** command.

To execute both tests one time:

```
pv 1
```

To execute test 2 with maximum debug output repeatedly until a ^C is entered:

```
pv -t2 -v9 0
```

To execute tests 3, 4, and 5 only for 2 cycles:

```
pv -t3-5 2
```

The results on a good system with the loopback test board connected, are as follows:

```
M>pv 1
```

```
Testing: E3499C Series Emulation System
```

```
Test 1: Powerup PV Results           Passed!
Test 2: Target Probe Feedback Test    Passed!
Test 3: Boundary Scan Master Test     Passed!
```

```
Test 4: I2C Test                Passed!  
Test 5: Data Lines Test        Passed!  
PASSED Number of tests: 1      Number of failures: 0
```

Copyright (c) Agilent Technologies 1987
All Rights Reserved. Reproduction, adaptation, or translation without prior
written permission is prohibited, except as allowed under copyright laws.

```
E3499C Series Emulation System  
Version:  A.07.51 17Dec97  
Location:  Generics
```

```
E3497A Motorola MPC800 Embedded PowerPC Emulator  
Version:  A.01.02 18Dec97
```

M>

You may get an error like "ERROR 172! Bad status code (0xff) from the hard
reset sequence" just before the prompt. This is because the selftest loopback
connector is installed instead of being connected to a real PowerPC target
system. You may also get a "?>" prompt for the same reason, and this is
normal and expected. Any errors after the "PASSED Number of tests: 1
Number of failures: 0" line can be ignored.

If a performance verification test fails

- Details of the failure can be obtained through using a -v option
("verbose" level) of 2 or more.
- Check that the loopback test board is connected.
- If the problem persists, contact Agilent Technologies for assistance.

Returning Parts to Agilent Technologies for Service

The repair strategy for this emulator is board replacement.

Exchange assemblies are available when a repairable assembly is returned to Agilent Technologies. These assemblies have been set up on the "Exchange Assembly" program. This lets you exchange a faulty assembly with one that has been repaired, calibrated, and performance verified by the factory. The cost is significantly less than that of a new assembly.

To return a part to Agilent Technologies

- 1** Follow the procedures in this chapter to make sure that the problem is caused by a hardware failure, not by configuration or cabling problems.
- 2** In the U.S., call 1-800-403-0801. Outside the U.S., call your nearest Agilent Technologies sales office. Ask them for the address of the nearest Agilent Technologies service center.
- 3** Package the part and send it to the Agilent Technologies service center.

Keep any parts which you know are working. For example, if only the target interface module is broken, keep the emulation module and cables.

- 4** When the part has been replaced, it will be sent back to you.

The unit returned to you will have the same serial number as the unit you sent to Agilent Technologies.

The Agilent Technologies service center can also troubleshoot the hardware and replace the failed part. To do this, send your entire measurement system to the service center, including the logic analysis system, target interface module, and cables.

In some parts of the world, on-site repair service is available. Ask an Agilent Technologies sales or service representative for details.

To obtain replacement parts

The following table lists some parts that may be replaced if they are damaged or lost. The part numbers are subject to change. Contact your nearest Agilent Technologies Sales Office for further information.

Part numbers

Exchange Assemblies

Part Number	Description
16600-69515	Emulation module
E3497-69401	Programmed emulation probe assembly

Replacement Assemblies

Part number	Description
E3496-61603	10-pin target cable
E3496-61601	50-pin cable
E3496-66502	Loopback test board
E3497-66502	Target Interface Module
16700-61608	Expansion cable for emulation module
0950-3043	Power supply for emulation probe

Cleaning the Instrument

If the instrument requires cleaning:

- 1** Remove power from the instrument.
- 2** Clean the instrument with a mild detergent and water.
- 3** Make sure that the instrument is completely dry before reconnecting it to a power source.

Glossary

Analysis Probe A probing solution connected to the target microprocessor. It provides an interface between the signals of the target microprocessor and the inputs of the logic analyzer. Formerly called a "preprocessor."

Elastomeric Probe Adapter A connector that is fastened on top of a target microprocessor using a retainer and knurled nut. The conductive elastomer on the bottom of the probe adapter makes contact with pins of the target microprocessor and delivers their signals to connection points on top of the probe adapter.

Emulation Module An emulation module is installed within the mainframe of a logic analyzer. It provides run control within an emulation and analysis test setup. See Emulation Probe.

Emulator. An emulation module or an emulation probe.

Emulation Probe An emulation probe is a standalone instrument connected to the mainframe of a logic analyzer. It provides run control within an emulation and analysis test setup. Formerly called a "processor probe" or "software probe." See Emulation Module.

Extender A part whose only function is to provide connections from one location to another. One or more extenders might be stacked to raise a probe above a target microprocessor to avoid mechanical contact with other components installed close to the target microprocessor. Sometimes called a "connector board."

Flexible Adapter Two connection devices coupled with a flexible cable. Used for connecting probing hardware on the target microprocessor to the analysis probe.

General-Purpose Flexible Adapter

A cable assembly that connects the signals from an elastomeric probe adapter to an analysis probe. Normally, a male-to-male header or transition board makes the connections from the general-purpose flexible adapter to the analysis probe.

High-Density Adapter Cable

A cable assembly that delivers signals from an analysis probe hardware interface to the logic analyzer pod cables. A high-density adapter cable has a single Mictor connector that is installed into the analysis probe, and two cables that are connected to corresponding odd and even logic analyzer pod cables.

High-Density Termination Adapter Cable

Same as a High-Density Adapter Cable, except it has a termination in the Mictor connector.

Jumper Moveable direct electrical connection between two points.

Mainframe Logic Analyzer A logic analyzer that resides on one or more board assemblies installed in an Agilent Technologies 16500, 1660x, or 16600A/700A-series mainframe.

Male-to-male Header A board assembly that makes point-to-point

connections between the female pins of a flexible adapter or transition board and the female pins of an analysis probe.

Preprocessor See Analysis Probe.

Preprocessor Interface See Analysis Probe.

Probe adapter See Elastomeric Probe Adapter.

Processor Probe See Emulation Probe.

Prototype Analyzer The Agilent Technologies 16505A prototype analyzer acts as an analysis and display processor for the Agilent Technologies 16500B/C logic analysis system. It provides a windowed interface and powerful analysis capabilities. Replaced by Agilent Technologies 16600A/700A-series logic analysis systems.

Run Control Probe See Emulation Probe and Emulation Module.

Setup Assistant A software program that guides a user through the process of connecting and configuring a logic analyzer to make measurements on a specific microprocessor.

Shunt Connector. See Jumper.

Software Probe See Emulation Probe.

Solution Agilent Technologies' term for a set of tools for debugging your target system. A solution includes probing, inverse assembly, the Agilent Technologies B4620B Source Correlation Tool Set, and possibly an emulation module.

Stand-alone Logic Analyzer A standalone logic analyzer has a pre-defined set of hardware components which provide a specific set of capabilities. It is designed to perform logic analysis. A standalone logic analyzer differs from a mainframe logic analyzer in that it does not offer card slots for installation of additional capabilities, and its specifications are not modified based upon selection from a set of optional hardware boards that might be installed within its frame.

Target Control Port An 8-bit, TTL port on a logic analysis system that you can use to send signals to your target system. It does not function like a pattern generator or emulation module, but more like a remote control for the target's switches.

Target Interface Module A small circuit board which connects the 50-pin cable from an emulation module or emulation probe to signals from the debug port on a target system.

TIM See Target Interface Module.

Trigger Specification A set of conditions that must be true before the instrument triggers. See the printed or online documentation for your logic analyzer for details.

Transition Board A board assembly that obtains signals connected to one side and rearranges them in a different order for delivery at the other side of the board.

1/4-Flexible Adapter An adapter that obtains one-quarter of the signals from an elastomeric probe adapter (one side of a target micro-processor) and makes them available for probing.

Index

A

- address, IP
 - See* IP address
- ADS board, configuring, 75
- altitude specifications, 116
- analysis probe
 - connecting to, 63
 - definition, 155
 - processors supported, 4
 - product numbers, 4

B

- BDM port
 - See* debug port
- BKG light, 120–122
- BNC
 - LAN, 29
- BNC, break in, 72
- BNC, LAN, 114
- BNC, trigger out, 72
- BOOTP, 34
- breakpoints
 - failure of, 135
 - tracing until, 104–106
- breaks
 - break in type, 71
 - effects of, 74
- built-in commands
 - configuration, 67
 - LAN configuration, 31
 - list of commands, 123–125

C

- cable
 - LAN, 36
 - power, 19
 - serial, 39
- cables
 - emulator, 62
 - replacing, 152
- CD-ROM, installing software from, 52
- cf commands, 67
- checklist, setup, 15
- cleaning, 153–154
- clock speed
 - configuring, 69

clocks

- qualified, and emulator, 97
- slow, 103–104
- specifications, 114
- configuration
 - flowchart, 15
 - configuration files
 - installing, 49–52
 - configuration registers, disabling, 74
 - configuration, emulator
 - overview, 64–77
 - using debugger, 68
- connection
 - emulation module, 43–48
 - emulator, 53–80
 - host workstation, 27–42, 81–90
 - problems, LAN, 127, 139–140
 - problems, RS-232, 129
- connector
 - 10BASE-T, 29–37, 86, 114
 - 10BASE2, 29–37, 86, 114
 - debug port, 59
 - serial, 114
- connector board, 155
- D**
 - data communications
 - specifications, 114
 - DCE or DTE selection and RS-232 cable, 129
 - debug port
 - connecting to, 62
 - connections, 59
 - debuggers
 - benefits of, 82
 - configuration, 68
 - setting up, 85–90
 - See also* under debugger name
 - writing, 125
 - DER register, 73
 - development port
 - See* debug port
 - directories
 - software installation, 52
 - displaying on PC, 89–90
 - download speed, configuring, 71
 - driver firmware error, 133

E

- elastomeric probe adapter
 - definition, 155
- Emulation Control Interface
 - configuration, 66
 - debugger conflict, 85
 - introduction, 55–57
 - when to use, 92
- emulation module
 - 16600 installation, 47
 - 16700A installation, 45
 - connecting, 44–48
 - definition, 155
 - description of, 3
 - port number, 87
 - product numbers, 4
- emulation probe
 - definition, 155
 - equipment required, 18
- emulator
 - configuration, 68
 - connecting, 54, 61–63
 - description of, 2
 - product numbers, 4
 - target system design, 58–60
 - equipment required
 - emulation migration, 24
 - emulation module, 22
 - equipment supplied
 - emulation migration, 23–24
 - emulation module, 21–22
 - emulation probe, 16
 - ordering information, 4
 - overview, 4
 - ethernet address, 31
 - examples, measurement, 93
 - exporting a display, 89–90
 - extender, 155

F

- files
 - loading vs. installing, 50
 - workstation setup, 85–90
- firmware
 - location of, 24
- firmware, updating, 108

-
- flash EPROM, 108
 - flexible adapter
 - definition, 155
 - flowchart, setup, 15
 - G**
 - gateway address, 32, 127
 - general-purpose flexible adapter
 - definition, 156
 - H**
 - high-density adapter cable
 - definition, 156
 - high-density termination adapter
 - definition, 156
 - host computer
 - connecting to, 27–42, 81–90
 - HRESET signal, 58–60
 - I**
 - IEEE 802.3, 29–37, 86
 - IMMR register, 73
 - information sources, 25–26
 - init command, 133
 - installation, emulation module, 43–48
 - installation, software, 49–52
 - intermodule measurement
 - creating, 96
 - intermodule measurement problems
 - analyzer doesn't stop, 97
 - internet address
 - See* IP address
 - interrupts
 - non-recoverable, 135
 - inverse assembly
 - displays, 93
 - IP address, 29–31, 86, 126–127
 - J**
 - jumper, definition, 156
 - L**
 - LAN
 - emulation module, 86
 - problems, 139–140
 - lan command, 31
 - LAN connection problems, 127, 145–146
 - LAN interface, 29–37
 - LAN parameters, configuring
 - BOOTP, 34
 - methods, 29
 - terminal interface, 31
 - lights
 - See* status lights
 - link beat, 36
 - link level address, 31, 34
 - LINK light, 121
 - listing windows, 93
 - loading configurations, vs. installing, 49–52
 - M**
 - mainframe logic analyzer
 - definition, 156
 - male-to-male header
 - definition, 156
 - mask, subnet, 128, 140
 - MAU, 29, 114
 - measurement examples, 93
 - microprocessors supported, 4
 - Motorola 860 ADS, configuring, 75
 - P**
 - PC
 - connecting to, 27–42
 - PC (personal computer)
 - connecting to, 81–90
 - performance verification test, 143, 148
 - ping command, 127
 - POL light, 121, 128
 - port number, 32
 - port number, emulation module, 87
 - port number, emulator, 123
 - power cord, 18–19
 - power failure during firmware update, 109
 - power on/off sequence, 20
 - power up self test, 141
 - preprocessor
 - See* analysis probe
 - prgflash, 108
 - probe, testing, 147
 - problems
 - emulator, 117–154
 - processor support package, 52
 - processor type, configuring, 69
 - processors supported, 4
 - prompts, 125
 - list of, 125
 - troubleshooting, 133
 - prototype analyzer
 - definition, 156
 - PV
 - See* performance verification
 - R**
 - real-time runs, configuring, 70
 - references, 25–26
 - register commands, 131
 - registers
 - configuring internal, 73
 - repair
 - emulator, 151–152
 - requirements
 - target system, 58–60
 - reset
 - effects of, 74, 137
 - light, 120–122
 - unexpected, 136
 - reset level, configuring, 70
 - RESET light, 121
 - RS-232
 - See* serial connection
 - run control tool
 - See* emulation control interface
 - S**
 - self test, 141
 - serial connection
 - DCE or DTE selection, 129
 - number of connections, 129
 - problems, 129
 - setting up, 38–42
 - verifying, 41
 - service ports, TCP, 32
 - service, how to obtain, 151
 - setup
 - See* configuration
 - Setup Assistant, 16
 - definition, 156
 - setup checklist, 15
 - signals
 - debug port, 59
 - skid, reducing, 97

-
- slow clock, 119
 - slow clock message, 103–104
 - software
 - installing, 49–52
 - list of installed, 51
 - software probe
 - See* emulation module
 - See* emulation probe
 - solution
 - definition, 157
 - source code
 - displays, 93
 - specifications
 - altitude, 116
 - clock, 114
 - data communications, 114
 - temperature, 116
 - trigger in/out, 114
 - SRESET signal, 58–60
 - StarLAN, 29, 36
 - status lights, 120–122, 141
 - subnet mask, 29, 127–128, 140
 - switches
 - bootp, 35
 - LAN configuration, 31, 36
 - serial configuration, 39
 - SYPICR register, 73
- T**
- target control port, 157
 - target interface module (TIM)
 - connecting, 62
 - definition, 157
 - target system
 - connecting to, 44–48, 54
 - problems with, 131–138
 - requirements for emulation, 58–60
 - telnet, 37, 88, 123, 126
 - temperature specifications, 116
 - terminal (MS Windows program), 129
 - terminal interface, 37, 88
 - See also* built-in commands
 - LAN parameters, setting, 31
 - tests, emulation module, 148–150
 - ThinLAN, 29, 114
 - transition board
 - definition, 157
 - trigger
 - emulation module, 95
 - in/out specifications, 114
 - on break, 99
 - troubleshooting, 119
 - emulator, 117–154
 - turning on power, 19
 - TX light, 121
- U**
- update, firmware, 108
 - USER light, 120–122
- W**
- watchdog timer, 73
 - web sites
 - logic analyzers, 25
 - See also* under debugger names
 - workstation
 - connecting to, 27–42
- X**
- X windows, 89–90

DECLARATION OF CONFORMITY

according to ISO/IEC Guide 22 and EN 45014

Manufacturer's Name: Agilent Technologies
Manufacturer's Address: Digital Design Product Generation Unit
1900 Garden of the Gods Road
Colorado Springs, CO 80907 USA

declares that the product

Product Name: Processor Probe
Model Number(s): E3497A
Product Option(s): All

conforms to the following Product Specifications:

Safety: IEC 1010-1:1990+A1 / EN 61010-1:1993
UL 3111
CSA-C22.2 No. 1010.1:1993

EMC: CISPR 11:1990 / EN 55011:1991 Group 1, Class A
IEC 555-2:1982 + A1:1985 / EN 60555-2:1987
IEC 555-3:1982 + A1:1990 / EN 60555-3:1987 + A1:1991
IEC 801-2:1991 / EN 50082-1:1992 4 kV CD, 8 kV AD
IEC 801-3:1984 / EN 50082-1:1992 3 V/m, {1kHz 80% AM, 27-1000 MHz}
IEC 801-4:1988 / EN 50082-1:1992 0.5 kV Sig. Lines, 1 kV Power Lines

Supplementary Information:

The product herewith complies with the requirements of the Low Voltage Directive 73/23/EEC and the EMC Directive 89/336/EEC and carries the CE marking accordingly.

This product was tested in a typical configuration with Agilent Technologies test systems.

Colorado Springs, 10/30/96

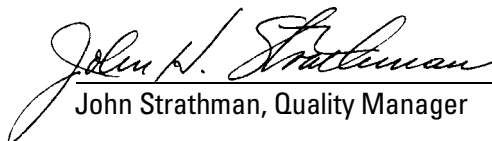
John Strathman, Quality Manager

European Contact: Your local Agilent Technologies Sales and Service Office or Agilent Technologies GmbH, Department ZQ / Standards Europe, Herrenberger Strasse 130, D-71034 Böblingen Germany (FAX: +49-7031-14-3143)

Product Regulations

Safety IEC 1010-1:1990+A1 / EN 61010-1:1993
UL 3111
CSA-C22.2 No.1010.1:1993

EMC This Product meets the requirement of the European Communities (EC)
EMC Directive 89/336/EEC.



Emissions EN55011/CISPR 11 (ISM, Group 1, Class A equipment)

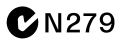

Immunity EN50082-1 Code¹ Notes²

IEC 801-2 (ESD) 4kV CD, 8kV AD	1	1
IEC 801-3 (Rad.) 3 V/m	1	
IEC 801-4 (EFT) 0.5 kV, 1kV	1	

¹ Performance Codes:

- 1 PASS - Normal operation, no effect.
- 2 PASS - Temporary degradation, self recoverable.
- 3 PASS - Temporary degradation, operator intervention required.
- 4 FAIL - Not recoverable, component damage.

² Notes:

- 1 The target cable assembly is sensitive to ESD events. Use standard ESD preventative practices to avoid component damage.

Sound Pressure Level N/A

Reproduction, adaptation, or translation without prior written permission is prohibited, except as allowed under the copyright laws.

Restricted Rights Legend

Use, duplication, or disclosure by the U.S. Government is subject to restrictions set forth in subparagraph (C) (1) (ii) of the Rights in Technical Data and Computer Software Clause in DFARS

252.227-7013. Agilent Technologies, 3000 Hanover Street, Palo Alto, CA 94304 U.S.A.

Rights for non-DOD U.S. Government Departments and Agencies are set forth in FAR 52.227-19(c)(1,2).

Document Warranty

The information contained in this document is subject to change without notice.

Agilent Technologies makes no warranty of any kind with regard to this material, including, but not limited to, the implied warranties of merchantability or fitness for a particular purpose.

Agilent Technologies shall not be liable for errors contained herein or for damages in connection with the furnishing, performance, or use of this material.

Safety

This apparatus has been designed and tested in accordance with IEC Publication 1010, Safety Requirements for Measuring Apparatus, and has been supplied in a safe condition. This is a Safety Class I instrument (provided with terminal for protective earthing). Before applying power, verify that the correct safety precautions are taken (see the following warnings). In addition, note the external markings on the instrument that are described under "Safety Symbols."

Warning

- Before turning on the instrument, you must connect the protective earth terminal of the instrument to the protective conductor of the (mains) power cord. The mains plug shall only be inserted in a socket outlet provided with a protective earth contact. You must not negate the protective action by using an extension cord (power cable) without a protective conductor (grounding). Grounding one conductor of a two-conductor outlet is not sufficient protection.
- Only fuses with the required rated current, voltage, and specified type (normal blow, time delay, etc.) should be used. Do not use repaired fuses or short-circuited fuseholders. To do so could cause a shock or fire hazard.

- Service instructions are for trained service personnel. To avoid dangerous electric shock, do not perform any service unless qualified to do so. Do not attempt internal service or adjustment unless another person, capable of rendering first aid and resuscitation, is present.

- If you energize this instrument by an auto transformer (for voltage reduction), make sure the common terminal is connected to the earth terminal of the power source.

- Whenever it is likely that the ground protection is impaired, you must make the instrument inoperative and secure it against any unintended operation.

- Do not operate the instrument in the presence of flammable gasses or fumes. Operation of any electrical instrument in such an environment constitutes a definite safety hazard.

- Do not install substitute parts or perform any unauthorized modification to the instrument.

- Capacitors inside the instrument may retain a charge even if the instrument is disconnected from its source of supply.

- Use caution when exposing or handling the CRT. Handling or replacing the CRT shall be done only by qualified maintenance personnel.

Safety Symbols



Instruction manual symbol: the product is marked with this symbol when it is necessary for you to refer to the instruction manual in order to protect against damage to the product.



Hazardous voltage symbol.



Earth terminal symbol: Used to indicate a circuit common connected to grounded chassis.

WARNING

The Warning sign denotes a hazard. It calls attention to a procedure, practice, or the like, which, if not correctly performed or adhered to, could result in personal injury. Do not proceed beyond a Warning sign until the indicated conditions are fully understood and met.

CAUTION

The Caution sign denotes a hazard. It calls attention to an operating procedure, practice, or the like, which, if not correctly performed or adhered to, could result in damage to or destruction of part or all of the product. Do not proceed beyond a Caution symbol until the indicated conditions are fully understood or met.

Product Warranty

This Agilent Technologies product has a warranty against defects in material and workmanship for a period of one year from date of shipment. During the warranty period, Agilent Technologies will, at its option, either repair or replace products that prove to be defective.

For warranty service or repair, this product must be returned to a service facility designated by Agilent Technologies.

For products returned to Agilent Technologies for warranty service, the Buyer shall prepay shipping charges to Agilent Technologies and Agilent Technologies shall pay shipping charges to return the product to the Buyer. However, the Buyer shall pay all shipping charges, duties, and taxes for products returned to Agilent Technologies from another country.

Agilent Technologies warrants that its software and firmware designated by Agilent Technologies for use with an instrument will execute its programming instructions when properly installed on that instrument. Agilent Technologies does not warrant that the operation of the instrument software, or firmware will be uninterrupted or error free.

Limitation of Warranty

The foregoing warranty shall not apply to defects resulting from improper or inadequate maintenance by the Buyer, Buyer-supplied software or interfacing, unauthorized modification or misuse, operation outside of the environmental specifications for the product, or improper site preparation or maintenance.

No other warranty is expressed or implied. Agilent Technologies specifically disclaims the implied warranties of merchantability or fitness for a particular purpose.

Exclusive Remedies

The remedies provided herein are the buyer's sole and exclusive remedies. Agilent Technologies shall not be liable for any direct, indirect, special, incidental, or consequential damages, whether based on contract, tort, or any other legal theory.

Assistance

Product maintenance agreements and other customer assistance agreements are available for Agilent Technologies products.

For any assistance, contact your nearest Agilent Technologies Sales Office.

Certification

Agilent Technologies certifies that this product met its published specifications at the time of shipment from the factory. Agilent Technologies further certifies that its calibration measurements are traceable to the United States National Institute of Standards and Technology, to the extent allowed by the Institute's calibration facility, and to the calibration facilities of other International Standards Organization members.

About this edition

This is the *Emulation for the Motorola Embedded PowerPC MPC800 User's Guide*.

Publication number
E3497-97006, May 2000
Printed in USA.

The information in this manual previously appeared in:

E3497-97001, March 1997
E3497-97004, August 1998
E3497-97005, January 1999

New editions are complete revisions of the manual. Many product updates do not require manual changes; and, conversely, manual corrections may be done without accompanying product changes. Therefore, do not expect a one-to-one correspondence between product updates and manual updates.

Comments welcome!

Send your comments or suggestions regarding this manual to:
documentation@col.hp.com

Reflection 1 is a U.S. trademark of Walker, Richer & Quinn, Inc.

UNIX is a registered trademark of The Open Group.

Windows, MS Windows, Windows NT, and MS-DOS are U.S. registered trademarks of Microsoft Corporation.

X/Open is a registered trademark, and the X device is a trademark of X/Open Company Ltd. in the UK and other countries.

MPC860 and MPC821 Embedded PowerPC microprocessors are products of Motorola, Inc.